

# 7SR224 Recloser Controller

Overcurrent Relay

## Document Release History

This document is issue **2010/05**. The list of revisions up to and including this issue is:

2008/11	First issue
2010/05	Second Issue. Document formatted due to rebrand

## Software Revision History



The copyright and other intellectual property rights in this document, and in any model or article produced from it (and including any registered or unregistered design rights) are the property of Siemens Protection Devices Limited. No part of this document shall be reproduced or modified or stored in another form, in any data retrieval system, without the permission of Siemens Protection Devices Limited, nor shall any model or article be reproduced from this document unless Siemens Protection Devices Limited consent.

While the information and guidance given in this document is believed to be correct, no liability shall be accepted for any loss or damage caused by any error or omission, whether such error or omission is the result of negligence or any other cause. Any and all such liability is disclaimed.

## Contents

1.	Function Diagram.....	3
2.	Menu Structure .....	4
2.1.	Relay Settings.....	5
2.2.	Systems Config.....	5
2.3.	CT/VT Config.....	6
2.4.	Function Config.....	7
2.5.	Current Prot'n .....	10
2.6.	.....	10
2.6.1.	Phase Overcurrent.....	10
2.6.2.	Voltage Cont O/C.....	15
2.6.3.	Cold Load .....	16
2.6.4.	Measured G/F.....	17
2.6.5.	Sensitive G/F .....	22
2.6.6.	Restricted G/F.....	26
2.6.7.	NPS Overcurrent .....	26
2.6.8.	Under Current.....	27
2.6.9.	Thermal.....	27
2.7.	Voltage Prot'n .....	28
2.7.1.	Phase U/O Voltage .....	28
2.7.2.	Vx U/O Voltage .....	30
2.7.3.	NPS Overvoltage.....	30
2.7.4.	Neutral Overvoltage.....	31
2.7.5.	U/O Frequency .....	32
2.8.	Supervision .....	34
2.8.1.	CB Fail .....	34
2.8.2.	VT Supervision .....	34
2.8.3.	CT Supervision .....	35
2.8.4.	Broken Conductor.....	35
2.8.5.	Trip CCT Supervision .....	36
2.8.6.	Inrush Detector .....	36
2.8.7.	Battery Test .....	36
2.8.8.	Capacitor Test .....	37
2.8.9.	Power Quality .....	37
2.8.10.	Demand .....	38
2.8.11.	Control & Logic .....	38
2.8.12.	Autoreclose Prot'n .....	38
2.8.13.	Autoreclose Config .....	39
2.8.14.	Manual Close.....	43
2.8.15.	Circuit Breaker .....	44
2.8.16.	LOV Automation .....	44
2.8.17.	Quick Logic.....	46
2.9.	Input Config .....	56
2.9.1.	Input Matrix .....	56
2.9.2.	Function Key Matrix .....	69
2.9.3.	Binary Input Config .....	69
2.9.4.	Function key Config .....	71
2.9.5.	General Alarms.....	71
2.10.	Output Config.....	72
2.10.1.	Output Matrix .....	72
2.10.2.	Binary Output Config .....	98
2.10.3.	LED Config .....	98
2.10.4.	Pickup Config.....	99
2.11.	CB Maintenance .....	99
2.11.1.	CB Counters .....	99
2.11.2.	I <sup>2</sup> T CB Wear .....	100
2.12.	Data Storage.....	101
2.13.	Communications.....	102
3.	Relay Instrumentation .....	103

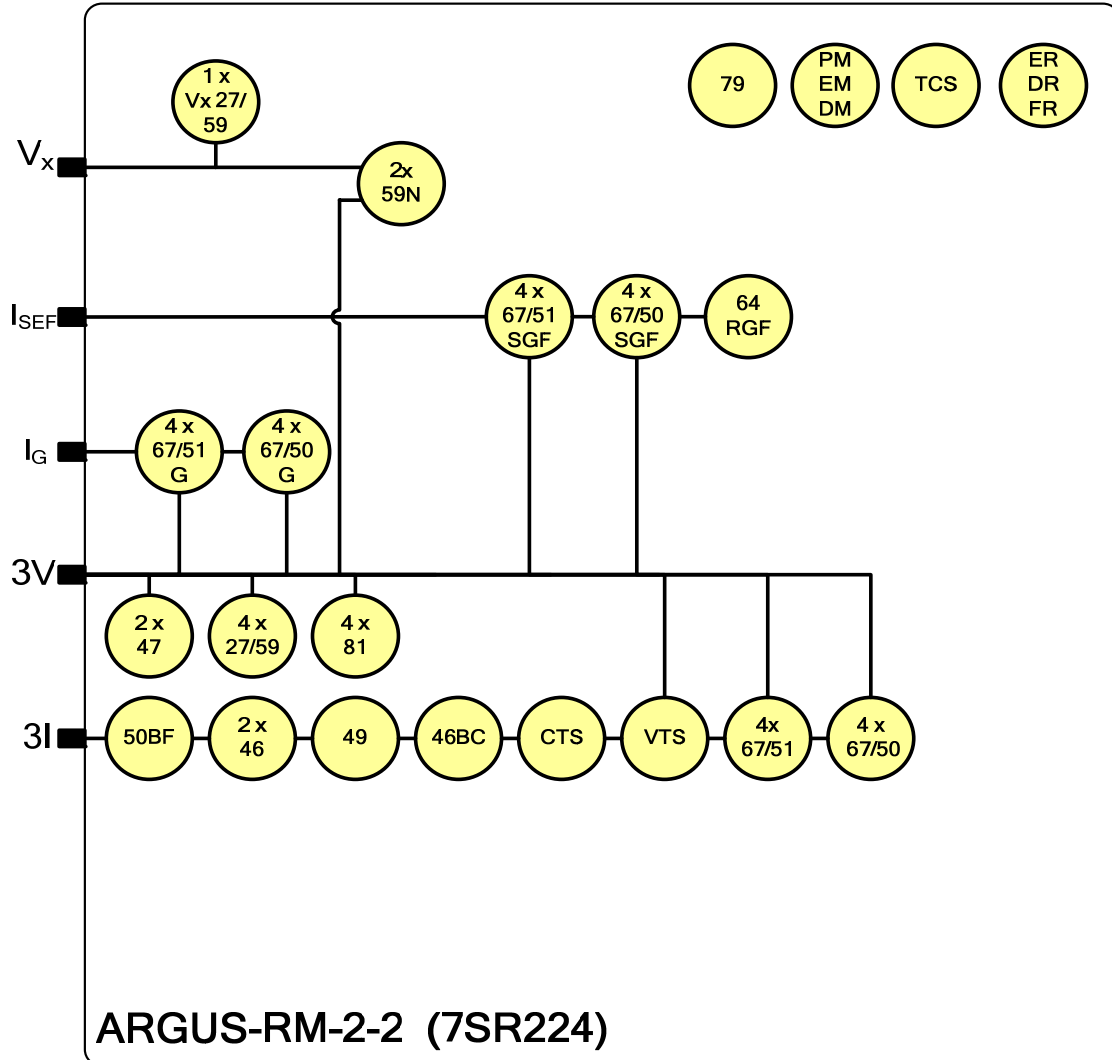
# 1. Function Diagram



## 2. Menu Structure

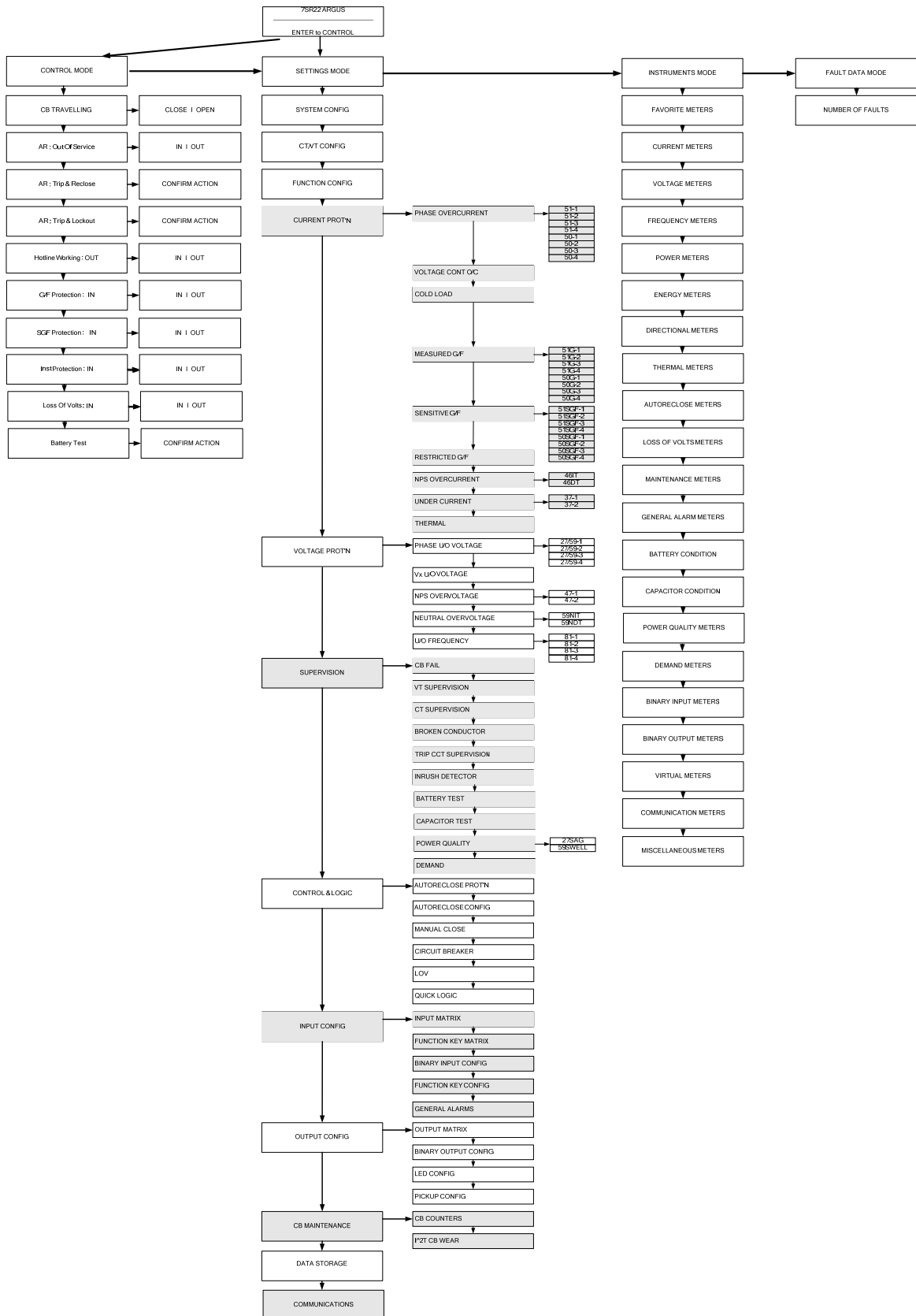

## 2.1. Relay Settings

## 2.2. Systems Config

Description	Range	Default	Setting
Language Setting <i>Selects the language in which the relay text will be displayed.</i>	English, USA-English	English	
Active Group <i>Selects which settings group is currently activated</i>	1,2...8	1	
System Frequency <i>Selects the Power System Frequency from 50 or 60 Hz</i>	50, 60	50Hz	
View/Edit Group <i>Selects which settings group is currently being displayed</i>	1,2...8	1	
Setting Dependencies <i>When enabled only active settings are displayed and all others hidden</i>	Disabled, Enabled	Enabled	
Favorite Meters Timer <i>Selects the time delay after which, if no key presses have been detected, the relay will begin to poll through any screens which have been selected as favorite instruments</i>	Off, 1, 2, 5, 10, 15, 30, 60	60min	
Backlight timer <i>Controls when the LCD backlight turns off</i>	Off, 1, 2, 5, 10, 15, 30, 60	5min	
Date <i>Sets the date, this setting can only be changed on the fascia or via Relay-&gt;Control-&gt;Set Time and Date</i>	dd/mm/yyyy	1/1/2000	
Time <i>Sets the time, this setting can only be changed on the fascia or via Relay-&gt;Control-&gt;Set Time and Date</i>	hh:mm:ss	00:00:00	
Curr Set Display <i>Select whether the Pickup values are shown in terms of x Nominal, Primary or Secondary values on the Relay Fascia</i>	xNom, Primary, Secondary	xNom	
G/F Curr Set Display <i>As Above</i>	xNom, Primary, Secondary	xNom	
Export Power/Lag VAR <i>Selects the signs required for exporting power and lagging VARs</i>	+ve/+ve, +ve/-ve, -ve/+ve, -ve/-ve	+ve/+ve	
Select Grp Mode <i>Mode of operation of the group change from status input. Edge triggered ignores the status input once it has changed to the relevant group, where as with Level triggered the relay will only stay in the group it has changed to whilst the status input is being driven, after which it returns to the previous group.</i>	Edge triggered, Level triggered	Edge triggered	

Description	Range	Default	Setting
Clock Sync. From BI <i>Real time clock may be synchronised using a binary input (See Clock Sync. in Binary Input Menu)</i>	Disabled, Seconds, Minutes	Minutes	
Operating Mode <i>Selects the current operating mode of the relay. This can also be changed by a binary input mode selection.</i>	Out Of Service, Local, Remote, Local Or Remote	Local Or Remote	
Setting Password <i>Allows a 4 character alpha code to be entered as the password. Note that the display shows a password dependant encrypted code on the second line of the display</i>	(Password)	NONE	
Control Password <i>As Above</i>	(Password)	NONE	
Trip Alert <i>When Enabled the occurrence of a Trip will cause the relay to display the Trip Alert Screen, the only way to leave this screen is by acknowledging the trip through the TEST/RESET button on the relay fascia</i>	Disabled, Enabled	Enabled	
Relay Identifier <i>An alphanumeric string shown on the LCD normally used to identifier the circuit the relay is attached to or the relays purpose</i>	(16 Character String)	RECLOSER-M 7SR22	

### 2.3. CT/VT Config

Description	Range	Default	Setting
Phase Nom Voltage <i>Selects the nominal voltage setting Vn of the voltage input</i>	40, 40.1 ... 159.9, 160	63.5V	
Phase Voltage Trim Magnitude <i>Allows trimming of voltage magnitude, the setting value should be the voltage required to be added to get back to Phase Nom Voltage.</i>	0, 0.1 ... 19.9, 20	0V	
Phase Voltage Trim Angle <i>Allows trimming of voltage angle, the setting value is added to the current voltage angle</i>	-45, -44.9 ... 44.9, 45	0deg	
Phase Voltage Config <i>Required to allow for different types of physical VT connections.</i>	Van,Vbn,Vcn, Vab,Vbc,3V0, Va,Vb,Vc	Van,Vbn,Vcn	
Phase VT Ratio <i>VT ratio to scale primary voltage instrument</i>	3300:40, 3300:40.5 ... 500000:159.5, 500000:160	132000:110	
Vx Nom Voltage <i>Selects the nominal voltage setting Vn of the voltage input</i>	40, 40.1 ... 159.9, 160	63.5V	
Vx Voltage Trim Magnitude <i>Allows trimming of voltage magnitude, the setting value should be the voltage required to be added to get back to Vx Nom Voltage.</i>	0, 0.1 ... 19.9, 20	0V	

Description	Range	Default	Setting
Vx Voltage Trim Angle <i>Allows trimming of voltage angle, the setting value is added to the current voltage angle</i>	-45, -44.9 ... 44.9, 45	0deg	
Vx VT Ratio <i>VT ratio to scale primary voltage instrument</i>	3300:40, 3300:40.5 ... 500000:159.5, 500000:160	132000:110	
Phase Current Input <i>Selects whether 1 or 5 Amp terminals are being used for phase inputs</i>	1, 5	1A	
Phase CT Ratio <i>Phase CT ratio to scale primary current instruments</i>	1:0.2, 1:0.21 ... 5000:6.9, 5000:7	2000:1	
Ground Current Input <i>Selects whether 1 or 5 Amp terminals are being used for Measured Ground inputs</i>	1, 5	1A	
Ground CT Ratio <i>Measured Ground CT ratio to scale primary current instruments</i>	1:0.2, 1:0.21 ... 5000:6.9, 5000:7	2000:1	

## 2.4. Function Config

Description	Range	Default	Setting
Gn Phase Overcurrent <i>When set to Disabled, no Phase Overcurrent elements will be functional and all associated settings will be hidden. (The Setting Dependencies setting being set to Disabled will make all settings visible but will not allow them to operate).</i>	Enabled, Disabled	Disabled	
Gn Voltage Cont O/C <i>When set to Disabled, no Voltage Cont O/C elements will be functional and all associated settings will be hidden. (The Setting Dependencies setting being set to Disabled will make all settings visible but will not allow them to operate).</i>	Enabled, Disabled	Disabled	
Gn Cold Load <i>When set to Disabled, no Cold Load elements will be functional and all associated settings will be hidden. (The Setting Dependencies setting being set to Disabled will make all settings visible but will not allow them to operate).</i>	Enabled, Disabled	Disabled	
Gn Measured G/F <i>When set to Disabled, no Measured G/F elements will be functional and all associated settings will be hidden. (The Setting Dependencies setting being set to Disabled will make all settings visible but will not allow them to operate).</i>	Enabled, Disabled	Disabled	
Gn Sensitive G/F <i>When set to Disabled, no Sensitive G/F elements will be functional and all associated settings will be hidden. (The Setting Dependencies setting being set to Disabled will make all settings visible but will not allow them to operate).</i>	Enabled, Disabled	Disabled	

<b>Description</b>	<b>Range</b>	<b>Default</b>	<b>Setting</b>
Gn Restricted G/F <i>When set to Disabled, no Restricted G/F elements will be functional and all associated settings will be hidden. (The Setting Dependencies setting being set to Disabled will make all settings visible but will not allow them to operate).</i>	Enabled, Disabled	Disabled	
Gn NPS Overcurrent <i>When set to Disabled, no NPS Overcurrent elements will be functional and all associated settings will be hidden. (The Setting Dependencies setting being set to Disabled will make all settings visible but will not allow them to operate).</i>	Enabled, Disabled	Disabled	
Gn Under Current <i>When set to Disabled, no Under Current elements will be functional and all associated settings will be hidden. (The Setting Dependencies setting being set to Disabled will make all settings visible but will not allow them to operate).</i>	Enabled, Disabled	Disabled	
Gn Thermal <i>When set to Disabled, no Thermal elements will be functional and all associated settings will be hidden. (The Setting Dependencies setting being set to Disabled will make all settings visible but will not allow them to operate).</i>	Enabled, Disabled	Disabled	
Gn Phase U/O Voltage <i>When set to Disabled, no Phase U/O Voltage elements will be functional and all associated settings will be hidden. (The Setting Dependencies setting being set to Disabled will make all settings visible but will not allow them to operate).</i>	Enabled, Disabled	Disabled	
Gn Vx U/O Voltage <i>When set to Disabled, no Vx U/O Voltage elements will be functional and all associated settings will be hidden. (The Setting Dependencies setting being set to Disabled will make all settings visible but will not allow them to operate).</i>	Enabled, Disabled	Disabled	
Gn NPS Overvoltage <i>When set to Disabled, no NPS Overvoltage elements will be functional and all associated settings will be hidden. (The Setting Dependencies setting being set to Disabled will make all settings visible but will not allow them to operate).</i>	Enabled, Disabled	Disabled	
Gn Neutral Overvoltage <i>When set to Disabled, no Neutral Overvoltage elements will be functional and all associated settings will be hidden. (The Setting Dependencies setting being set to Disabled will make all settings visible but will not allow them to operate).</i>	Enabled, Disabled	Disabled	



<b>Description</b>	<b>Range</b>	<b>Default</b>	<b>Setting</b>
Gn U/O Frequency <i>When set to Disabled, no U/O Frequency elements will be functional and all associated settings will be hidden. (The Setting Dependencies setting being set to Disabled will make all settings visible but will not allow them to operate).</i>	Enabled, Disabled	Disabled	
Gn CB Fail <i>When set to Disabled, no CB Fail elements will be functional and all associated settings will be hidden. (The Setting Dependencies setting being set to Disabled will make all settings visible but will not allow them to operate).</i>	Enabled, Disabled	Disabled	
Gn VT Supervision <i>When set to Disabled, no VT Supervision elements will be functional and all associated settings will be hidden. (The Setting Dependencies setting being set to Disabled will make all settings visible but will not allow them to operate).</i>	Enabled, Disabled	Disabled	
Gn CT Supervision <i>When set to Disabled, no CT Supervision elements will be functional and all associated settings will be hidden. (The Setting Dependencies setting being set to Disabled will make all settings visible but will not allow them to operate).</i>	Enabled, Disabled	Disabled	
Gn Broken Conductor <i>When set to Disabled, no Broken Conductor elements will be functional and all associated settings will be hidden. (The Setting Dependencies setting being set to Disabled will make all settings visible but will not allow them to operate).</i>	Enabled, Disabled	Disabled	
Gn Trip Cct Supervision <i>When set to Disabled, no Trip Cct Supervision elements will be functional and all associated settings will be hidden. (The Setting Dependencies setting being set to Disabled will make all settings visible but will not allow them to operate).</i>	Enabled, Disabled	Disabled	
Gn Inrush Detector <i>When set to Disabled, no Inrush Detector elements will be functional and all associated settings will be hidden. (The Setting Dependencies setting being set to Disabled will make all settings visible but will not allow them to operate).</i>	Enabled, Disabled	Disabled	
Gn CB Counters <i>When set to Disabled, no Gn CB Counter elements will be functional and all associated settings will be hidden. (The Setting Dependencies setting being set to Disabled will make all settings visible but will not allow them to operate).</i>	Enabled, Disabled	Disabled	

Description	Range	Default	Setting
Gn I <sup>2</sup> t CB Wear <i>When set to Disabled, no Gn I<sup>2</sup>t CB Wear elements will be functional and all associated settings will be hidden. (The Setting Dependencies setting being set to Disabled will make all settings visible but will not allow them to operate).</i>	Enabled, Disabled	Disabled	
Gn Battery Test <i>When set to Disabled, no Battery Test elements will be functional and all associated settings will be hidden. (The Setting Dependencies setting being set to Disabled will make all settings visible but will not allow them to operate).</i>	Enabled, Disabled	Disabled	
Gn Capacitor Test <i>When set to Disabled, no Capacitor Test elements will be functional and all associated settings will be hidden. (The Setting Dependencies setting being set to Disabled will make all settings visible but will not allow them to operate).</i>	Enabled, Disabled	Disabled	
Gn LOV Automation <i>When set to Disabled, no LOV Automation elements will be functional and all associated settings will be hidden. (The Setting Dependencies setting being set to Disabled will make all settings visible but will not allow them to operate).</i>	Enabled, Disabled	Disabled	
Gn 27Sag & 59Swell <i>When set to Disabled, no 27Sag &amp; 59Swell elements will be functional and all associated settings will be hidden. (The Setting Dependencies setting being set to Disabled will make all settings visible but will not allow them to operate).</i>	Enabled, Disabled	Disabled	
Gn Demand <i>When set to Disabled, no Demand elements will be functional and all associated settings will be hidden. (The Setting Dependencies setting being set to Disabled will make all settings visible but will not allow them to operate).</i>	Enabled, Disabled	Disabled	

## 2.5. Current Prot'n

### 2.6.

#### 2.6.1. Phase Overcurrent

Description	Range	Default	Setting
Gn 67 Char Angle <i>Maximum torque angle for phase overcurrent elements</i>	-95, -94 ... 94, 95	45deg	
Gn 67 Minimum Voltage <i>Selects the directional elements minimum voltage, below which the element will be inhibited</i>	1, 1.5 ... 19.5, 20	1V	

Description	Range	Default	Setting
Gn 67 2-out-of-3 Logic <i>Selects whether 2 out of 3 voting logic is enabled for phase overcurrent elements</i>	Enabled, Disabled	Disabled	
Gn 51/50 Measurement <i>Selects whether the RMS value used by the 51 &amp; 50 elements is True RMS or only calculated at fundamental frequency</i>	RMS, Fundamental	RMS	

## 2.6.1.1. 51-1

Description	Range	Default	Setting
Gn 51-1 Element <i>Selects whether the 51-1 IDMTL Overcurrent element is enabled</i>	Disabled, Enabled	Disabled	
Gn 51-1 Dir. Control <i>Selects whether 51-1 element is non-directional, forward or reverse</i>	Non-Dir, Forward, Reverse	Non-Dir	
Gn 51-1 Setting <i>Pickup level</i>	0.05, 0.1 ... 2.45, 2.5	1xIn	
Gn 51-1 TCC <i>Selects characteristic curve to be IEC or ANSI IDMTL or DTL</i>	DTL, IEC-NI ... 201, 202	IEC-NI	
Gn 51-1 Time Mult (IEC/ANSI) <i>Time multiplier (applicable to IEC and ANSI curves but not DTL selection)</i>	0.025, 0.05 ... 1.575, 1.6	1	
Gn 51-1 Delay (DTL) <i>Delay (applicable only when DTL is selected for characteristic)</i>	0, 0.01 ... 19.99, 20	5s	
Gn 51-1 Min Operate Time <i>Minimum operate time of element.</i>	0, 0.01 ... 19.99, 20	0s	
Gn 51-1 Additional Time <i>Additional definite time added after characteristic time</i>	0, 0.01 ... 19.99, 20	0s	
Gn 51-1 Reset <i>Selects between an ANSI decaying reset characteristic or a definite time reset</i>	(ANSI) Decaying, 0 ... 59, 60	0s	
Gn 51-1 VTS Action <i>Selects whether 51-1 element is blocked or made non-directional when VTS operates</i>	Off, Inhibit, Non-Dir	Off	
Gn 51-1 Inrush Action <i>Selects if the 51-1 element is blocked from operating when 2nd Harmonic Inrush Detector operates</i>	Off, Inhibit	Off	

## 2.6.1.2. 51-2

Description	Range	Default	Setting
Gn 51-2 Element <i>Selects whether the 51-2 IDMTL Overcurrent element is enabled</i>	Disabled, Enabled	Disabled	
Gn 51-2 Dir. Control <i>Selects whether 51-2 element is non-directional, forward or reverse</i>	Non-Dir, Forward, Reverse	Non-Dir	

Description	Range	Default	Setting
Gn 51-2 Setting <i>Pickup level</i>	0.05, 0.1 ... 2.45, 2.5	1xIn	
Gn 51-2 TCC <i>Selects characteristic curve to be IEC or ANSI IDMTL or DTL</i>	DTL, IEC-NI ... 201, 202	IEC-NI	
Gn 51-2 Time Mult (IEC/ANSI) <i>Time multiplier (applicable to IEC and ANSI curves but not DTL selection)</i>	0.025, 0.05 ... 1.575, 1.6	1	
Gn 51-2 Delay (DTL) <i>Delay (applicable only when DTL is selected for characteristic)</i>	0, 0.01 ... 19.99, 20	5s	
Gn 51-2 Min Operate Time <i>Minimum operate time of element.</i>	0, 0.01 ... 19.99, 20	0s	
Gn 51-2 Additional Time <i>Additional definite time added after characteristic time</i>	0, 0.01 ... 19.99, 20	0s	
Gn 51-2 Reset <i>Selects between an ANSI decaying reset characteristic or a definite time reset</i>	(ANSI) Decaying, 0 ... 59, 60	0s	
Gn 51-2 VTS Action <i>Selects whether 51-2 element is blocked or made non-directional when VTS operates</i>	Off, Inhibit, Non-Dir	Off	
Gn 51-2 Inrush Action <i>Selects if the 51-2 element is blocked from operating when 2nd Harmonic Inrush Detector operates</i>	Off, Inhibit	Off	

## 2.6.1.3. 51-3

Description	Range	Default	Setting
Gn 51-3 Element <i>Selects whether the 51-3 IDMTL Overcurrent element is enabled</i>	Disabled, Enabled	Disabled	
Gn 51-3 Dir. Control <i>Selects whether 51-3 element is non-directional, forward or reverse</i>	Non-Dir, Forward, Reverse	Non-Dir	
Gn 51-3 Setting <i>Pickup level</i>	0.05, 0.1 ... 2.45, 2.5	1xIn	
Gn 51-3 TCC <i>Selects characteristic curve to be IEC or ANSI IDMTL or DTL</i>	DTL, IEC-NI ... 201, 202	IEC-NI	
Gn 51-3 Time Mult (IEC/ANSI) <i>Time multiplier (applicable to IEC and ANSI curves but not DTL selection)</i>	0.025, 0.05 ... 1.575, 1.6	1	
Gn 51-3 Delay (DTL) <i>Delay (applicable only when DTL is selected for characteristic)</i>	0, 0.01 ... 19.99, 20	5s	
Gn 51-3 Min Operate Time <i>Minimum operate time of element.</i>	0, 0.01 ... 19.99, 20	0s	
Gn 51-3 Additional Time <i>Additional definite time added after characteristic time</i>	0, 0.01 ... 19.99, 20	0s	

Description	Range	Default	Setting
Gn 51-3 Reset <i>Selects between an ANSI decaying reset characteristic or a definite time reset</i>	(ANSI) Decaying, 0 ... 59, 60	0s	
Gn 51-3 VTS Action <i>Selects whether 51-3 element is blocked or made non-directional when VTS operates</i>	Off, Inhibit, Non-Dir	Off	
Gn 51-3 Inrush Action <i>Selects if the 51-3 element is blocked from operating when 2nd Harmonic Inrush Detector operates</i>	Off, Inhibit	Off	

## 2.6.1.4. 51-4

Description	Range	Default	Setting
Gn 51-4 Element <i>Selects whether the 51-4 IDMTL Overcurrent element is enabled</i>	Disabled, Enabled	Disabled	
Gn 51-4 Dir. Control <i>Selects whether 51-4 element is non-directional, forward or reverse</i>	Non-Dir, Forward, Reverse	Non-Dir	
Gn 51-4 Setting <i>Pickup level</i>	0.05, 0.1 ... 2.45, 2.5	1xIn	
Gn 51-4 TCC <i>Selects characteristic curve to be IEC or ANSI IDMTL or DTL</i>	DTL, IEC-NI ... 201, 202	IEC-NI	
Gn 51-4 Time Mult (IEC/ANSI) <i>Time multiplier (applicable to IEC and ANSI curves but not DTL selection)</i>	0.025, 0.05 ... 1.575, 1.6	1	
Gn 51-4 Delay (DTL) <i>Delay (applicable only when DTL is selected for characteristic)</i>	0, 0.01 ... 19.99, 20	5s	
Gn 51-4 Min Operate Time <i>Minimum operate time of element.</i>	0, 0.01 ... 19.99, 20	0s	
Gn 51-4 Additional Time <i>Additional definite time added after characteristic time</i>	0, 0.01 ... 19.99, 20	0s	
Gn 51-4 Reset <i>Selects between an ANSI decaying reset characteristic or a definite time reset</i>	(ANSI) Decaying, 0 ... 59, 60	0s	
Gn 51-4 VTS Action <i>Selects whether 51-4 element is blocked or made non-directional when VTS operates</i>	Off, Inhibit, Non-Dir	Off	
Gn 51-4 Inrush Action <i>Selects if the 51-4 element is blocked from operating when 2nd Harmonic Inrush Detector operates</i>	Off, Inhibit	Off	

## 2.6.1.5. 50-1

Description	Range	Default	Setting
Gn 50-1 Element <i>Selects whether the INST/ DTL Overcurrent element is enabled</i>	Disabled, Enabled	Disabled	

Description	Range	Default	Setting
Gn 50-1 Dir. Control <i>Selects whether 50-1 element is non-directional, forward or reverse</i>	Non-Dir, Forward, Reverse	Non-Dir	
Gn 50-1 Setting <i>Pickup level</i>	0.05, 0.1 ... 49.5, 50	1xIn	
Gn 50-1 Delay <i>Sets operate delay time</i>	0, 0.01 ... 14300, 14400	0s	
Gn 50-1 VTS Action <i>Selects whether 50-1 element is blocked or made non-directional when VTS operates</i>	Off, Inhibit, Non-Dir	Off	
Gn 50-1 Inrush Action <i>Selects if the 50-1 element is blocked from operating when 2nd Harmonic Inrush Detector operates</i>	Off, Inhibit	Off	

## 2.6.1.6. 50-2

Description	Range	Default	Setting
Gn 50-2 Element <i>Selects whether the INST/ DTL Overcurrent element is enabled</i>	Disabled, Enabled	Disabled	
Gn 50-2 Dir. Control <i>Selects whether 50-2 element is non-directional, forward or reverse</i>	Non-Dir, Forward, Reverse	Non-Dir	
Gn 50-2 Setting <i>Pickup level</i>	0.05, 0.1 ... 49.5, 50	1xIn	
Gn 50-2 Delay <i>Sets operate delay time</i>	0, 0.01 ... 14300, 14400	0s	
Gn 50-2 VTS Action <i>Selects whether 50-2 element is blocked or made non-directional when VTS operates</i>	Off, Inhibit, Non-Dir	Off	
Gn 50-2 Inrush Action <i>Selects if the 50-2 element is blocked from operating when 2nd Harmonic Inrush Detector operates</i>	Off, Inhibit	Off	

## 2.6.1.7. 50-3

Description	Range	Default	Setting
Gn 50-3 Element <i>Selects whether the INST/ DTL Overcurrent element is enabled</i>	Disabled, Enabled	Disabled	
Gn 50-3 Dir. Control <i>Selects whether 50-3 element is non-directional, forward or reverse</i>	Non-Dir, Forward, Reverse	Non-Dir	
Gn 50-3 Setting <i>Pickup level</i>	0.05, 0.1 ... 49.5, 50	1xIn	
Gn 50-3 Delay <i>Sets operate delay time</i>	0, 0.01 ... 14300, 14400	0s	
Gn 50-3 VTS Action <i>Selects whether 50-3 element is blocked or made non-directional when VTS operates</i>	Off, Inhibit, Non-Dir	Off	

Description	Range	Default	Setting
Gn 50-3 Inrush Action <i>Selects if the 50-3 element is blocked from operating when 2nd Harmonic Inrush Detector operates</i>	Off, Inhibit	Off	

## 2.6.1.8. 50-4

Description	Range	Default	Setting
Gn 50-4 Element <i>Selects whether the INST/ DTL Overcurrent element is enabled</i>	Disabled, Enabled	Disabled	
Gn 50-4 Dir. Control <i>Selects whether 50-4 element is non-directional, forward or reverse</i>	Non-Dir, Forward, Reverse	Non-Dir	
Gn 50-4 Setting <i>Pickup level</i>	0.05, 0.1 ... 49.5, 50	1xIn	
Gn 50-4 Delay <i>Sets operate delay time</i>	0, 0.01 ... 14300, 14400	0s	
Gn 50-4 VTS Action <i>Selects whether 50-4 element is blocked or made non-directional when VTS operates</i>	Off, Inhibit, Non-Dir	Off	
Gn 50-4 Inrush Action <i>Selects if the 50-4 element is blocked from operating when 2nd Harmonic Inrush Detector operates</i>	Off, Inhibit	Off	

## 2.6.2. Voltage Cont O/C

Description	Range	Default	Setting
Gn 51V Element <i>Selects whether the Voltage Controlled Overcurrent element is enabled</i>	Disabled, Enabled	Disabled	
Gn 51V Setting <i>The voltage below which 51V operates</i>	5, 5.5 ... 199.5, 200	30V	
Gn 51V VTS Action <i>Selects whether or not the 51V element is blocked when VTS operates</i>	Off, Inhibit	Off	
Gn 51-1 Multiplier <i>Multiplier applied to the 51-1 element when VCO element has operated</i>	0.25, 0.3, 0.35, 0.4, 0.45, 0.5, 0.55, 0.6, 0.65, 0.7, 0.75, 0.8, 0.85, 0.9, 0.95, 1	0.5	
Gn 51-2 Multiplier <i>Multiplier applied to the 51-2 element when VCO element has operated</i>	0.25, 0.3, 0.35, 0.4, 0.45, 0.5, 0.55, 0.6, 0.65, 0.7, 0.75, 0.8, 0.85, 0.9, 0.95, 1	0.5	
Gn 51-3 Multiplier <i>Multiplier applied to the 51-3 element when VCO element has operated</i>	0.25, 0.3, 0.35, 0.4, 0.45, 0.5, 0.55, 0.6, 0.65, 0.7, 0.75, 0.8, 0.85, 0.9, 0.95, 1	0.5	
Gn 51-4 Multiplier <i>Multiplier applied to the 51-4 element when VCO element has operated</i>	0.25, 0.3, 0.35, 0.4, 0.45, 0.5, 0.55, 0.6, 0.65, 0.7, 0.75, 0.8, 0.85, 0.9, 0.95, 1	0.5	

## 2.6.3. Cold Load

Description	Range	Default	Setting
Cold Load <i>Selects whether the Cold Load element is enabled</i>	Disabled, Enabled	Disabled	
Pick-up Time <i>Cold Load operate time delay</i>	1, 1.1 ... 14100, 14400	600s	
Drop-off Time <i>Cold Load reset time delay</i>	1, 1.1 ... 14100, 14400	600s	
Reduced Current <i>Selects whether reduced current functionality is to be used</i>	Disabled, Enabled	Disabled	
Reduced Current Level <i>Selects current level below which Reduced Current Time is used for Cold Load reset delay</i>	0.05, 0.1 ... 2.45, 2.5	0.25xIn	
Reduced Current Time <i>Cold Load reset time delay used when reduced current active</i>	1, 1.1 ... 14100, 14400	600s	
Gn 51c-1 Setting <i>51-1 element parameter used when Cold Load operates</i>	0.05, 0.1 ... 2.45, 2.5	1xIn	
Gn 51c-1 TCC <i>As Above</i>	DTL, IEC-NI ... 201, 202	IEC-NI	
Gn 51c-1 Time Mult (IEC/ANSI) <i>As Above</i>	0.025, 0.05 ... 1.575, 1.6	1	
Gn 51c-1 Delay (DTL) <i>As Above</i>	0, 0.01 ... 19.99, 20	5s	
Gn 51c-1 Min Operate Time <i>As Above</i>	0, 0.01 ... 19.99, 20	0s	
Gn 51c-1 Additional Time <i>As Above</i>	0, 0.01 ... 19.99, 20	0s	
Gn 51c-1 Reset <i>As Above</i>	(ANSI) Decaying, 0 ... 59, 60	0s	
Gn 51c-2 Setting <i>51-2 element parameter used when Cold Load operates</i>	0.05, 0.1 ... 2.45, 2.5	1xIn	
Gn 51c-2 TCC <i>As Above</i>	DTL, IEC-NI ... 201, 202	IEC-NI	
Gn 51c-2 Time Mult (IEC/ANSI) <i>As Above</i>	0.025, 0.05 ... 1.575, 1.6	1	
Gn 51c-2 Delay (DTL) <i>As Above</i>	0, 0.01 ... 19.99, 20	5s	
Gn 51c-2 Min Operate Time <i>As Above</i>	0, 0.01 ... 19.99, 20	0s	
Gn 51c-2 Additional Time <i>As Above</i>	0, 0.01 ... 19.99, 20	0s	
Gn 51c-2 Reset <i>As Above</i>	(ANSI) Decaying, 0 ... 59, 60	0s	



Description	Range	Default	Setting
Gn 51c-3 Setting <i>51-3 element parameter used when Cold Load operates</i>	0.05, 0.1 ... 2.45, 2.5	1xIn	
Gn 51c-3 TCC <i>As Above</i>	DTL, IEC-NI ... 201, 202	IEC-NI	
Gn 51c-3 Time Mult (IEC/ANSI) <i>As Above</i>	0.025, 0.05 ... 1.575, 1.6	1	
Gn 51c-3 Delay (DTL) <i>As Above</i>	0, 0.01 ... 19.99, 20	5s	
Gn 51c-3 Min Operate Time <i>As Above</i>	0, 0.01 ... 19.99, 20	0s	
Gn 51c-3 Additional Time <i>As Above</i>	0, 0.01 ... 19.99, 20	0s	
Gn 51c-3 Reset <i>As Above</i>	(ANSI) Decaying, 0 ... 59, 60	0s	
Gn 51c-4 Setting <i>51-4 element parameter used when Cold Load operates</i>	0.05, 0.1 ... 2.45, 2.5	1xIn	
Gn 51c-4 TCC <i>As Above</i>	DTL, IEC-NI ... 201, 202	IEC-NI	
Gn 51c-4 Time Mult (IEC/ANSI) <i>As Above</i>	0.025, 0.05 ... 1.575, 1.6	1	
Gn 51c-4 Delay (DTL) <i>As Above</i>	0, 0.01 ... 19.99, 20	5s	
Gn 51c-4 Min Operate Time <i>As Above</i>	0, 0.01 ... 19.99, 20	0s	
Gn 51c-4 Additional Time <i>As Above</i>	0, 0.01 ... 19.99, 20	0s	
Gn 51c-4 Reset <i>As Above</i>	(ANSI) Decaying, 0 ... 59, 60	0s	

## 2.6.4. Measured G/F

Description	Range	Default	Setting
Gn 67G Char Angle <i>Maximum torque angle for measured ground fault elements</i>	-95, -94 ... 94, 95	-15deg	
Gn 67G Minimum Voltage <i>Selects the directional elements minimum voltage, below which the element will be inhibited</i>	0.33, 0.5, 1, 1.5, 2, 2.5, 3	0.33V	
Gn 51G/50G Measurement <i>Selects whether the RMS value used by the 51G &amp; 50G elements is True RMS or only calculated at fundamental frequency</i>	RMS, Fundamental	RMS	

## 2.6.4.1. 51G-1

Description	Range	Default	Setting
Gn 51G-1 Element <i>Selects whether the 51G-1 IDMTL measured Ground Fault element is enabled</i>	Disabled, Enabled	Disabled	

Description	Range	Default	Setting
Gn 51G-1 Dir. Control <i>Selects whether 51G-1 element is non-directional, forward or reverse</i>	Non-Dir, Forward, Reverse	Non-Dir	
Gn 51G-1 Setting <i>Pickup level</i>	0.005, 0.01 ... 0.995, 1	0.5xIn	
Gn 51G-1 TCC <i>Selects characteristic curve to be IEC or ANSI IDMTL or DTL</i>	DTL, IEC-NI ... 201, 202	IEC-NI	
Gn 51G-1 Time Mult (IEC/ANSI) <i>Time multiplier (applicable to IEC and ANSI curves but not DTL selection)</i>	0.025, 0.05 ... 1.575, 1.6	1	
Gn 51G-1 Delay (DTL) <i>Delay (applicable only when DTL is selected for characteristic)</i>	0, 0.01 ... 19.99, 20	5s	
Gn 51G-1 Min Operate Time <i>Minimum operate time of element.</i>	0, 0.01 ... 19.99, 20	0s	
Gn 51G-1 Additional Time <i>Additional definite time added after characteristic time</i>	0, 0.01 ... 19.99, 20	0s	
Gn 51G-1 Reset <i>Selects between an ANSI decaying reset characteristic or DTL reset</i>	(ANSI) Decaying, 0 ... 59, 60	0s	
Gn 51G-1 VTS Action <i>Selects whether 51G-1 element is blocked or made non-directional when VTS operates</i>	Off, Inhibit, Non-Dir	Off	
Gn 51G-1 Inrush Action <i>Selects if the 51G-1 element is blocked from operating when 2nd Harmonic Inrush Detector operates</i>	Off, Inhibit	Off	

## 2.6.4.2. 51G-2

Description	Range	Default	Setting
Gn 51G-2 Element <i>Selects whether the 51G-2 IDMTL measured Ground Fault element is enabled</i>	Disabled, Enabled	Disabled	
Gn 51G-2 Dir. Control <i>Selects whether 51G-2 element is non-directional, forward or reverse</i>	Non-Dir, Forward, Reverse	Non-Dir	
Gn 51G-2 Setting <i>Pickup level</i>	0.005, 0.01 ... 0.995, 1	0.5xIn	
Gn 51G-2 TCC <i>Selects characteristic curve to be IEC or ANSI IDMTL or DTL</i>	DTL, IEC-NI ... 201, 202	IEC-NI	
Gn 51G-2 Time Mult (IEC/ANSI) <i>Time multiplier (applicable to IEC and ANSI curves but not DTL selection)</i>	0.025, 0.05 ... 1.575, 1.6	1	
Gn 51G-2 Delay (DTL) <i>Delay (applicable only when DTL is selected for characteristic)</i>	0, 0.01 ... 19.99, 20	5s	
Gn 51G-2 Min Operate Time <i>Minimum operate time of element.</i>	0, 0.01 ... 19.99, 20	0s	

Description	Range	Default	Setting
Gn 51G-2 Additional Time <i>Additional definite time added after characteristic time</i>	0, 0.01 ... 19.99, 20	0s	
Gn 51G-2 Reset <i>Selects between an ANSI decaying reset characteristic or DTL reset</i>	(ANSI) Decaying, 0 ... 59, 60	0s	
Gn 51G-2 VTS Action <i>Selects whether 51G-2 element is blocked or made non-directional when VTS operates</i>	Off, Inhibit, Non-Dir	Off	
Gn 51G-2 Inrush Action <i>Selects if the 51G-2 element is blocked from operating when 2nd Harmonic Inrush Detector operates</i>	Off, Inhibit	Off	

## 2.6.4.3. 51G-3

Description	Range	Default	Setting
Gn 51G-3 Element <i>Selects whether the 51G-3 IDMTL measured Ground Fault element is enabled</i>	Disabled, Enabled	Disabled	
Gn 51G-3 Dir. Control <i>Selects whether 51G-3 element is non-directional, forward or reverse</i>	Non-Dir, Forward, Reverse	Non-Dir	
Gn 51G-3 Setting <i>Pickup level</i>	0.005, 0.01 ... 0.995, 1	0.5xIn	
Gn 51G-3 TCC <i>Selects characteristic curve to be IEC or ANSI IDMTL or DTL</i>	DTL, IEC-NI ... 201, 202	IEC-NI	
Gn 51G-3 Time Mult (IEC/ANSI) <i>Time multiplier (applicable to IEC and ANSI curves but not DTL selection)</i>	0.025, 0.05 ... 1.575, 1.6	1	
Gn 51G-3 Delay (DTL) <i>Delay (applicable only when DTL is selected for characteristic)</i>	0, 0.01 ... 19.99, 20	5s	
Gn 51G-3 Min Operate Time <i>Minimum operate time of element.</i>	0, 0.01 ... 19.99, 20	0s	
Gn 51G-3 Additional Time <i>Additional definite time added after characteristic time</i>	0, 0.01 ... 19.99, 20	0s	
Gn 51G-3 Reset <i>Selects between an ANSI decaying reset characteristic or DTL reset</i>	(ANSI) Decaying, 0 ... 59, 60	0s	
Gn 51G-3 VTS Action <i>Selects whether 51G-3 element is blocked or made non-directional when VTS operates</i>	Off, Inhibit, Non-Dir	Off	
Gn 51G-3 Inrush Action <i>Selects if the 51G-3 element is blocked from operating when 2nd Harmonic Inrush Detector operates</i>	Off, Inhibit	Off	

## 2.6.4.4. 51G-4

Description	Range	Default	Setting
-------------	-------	---------	---------

Description	Range	Default	Setting
Gn 51G-4 Element <i>Selects whether the 51G-4 IDMTL measured Ground Fault element is enabled</i>	Disabled, Enabled	Disabled	
Gn 51G-4 Dir. Control <i>Selects whether 51G-4 element is non-directional, forward or reverse</i>	Non-Dir, Forward, Reverse	Non-Dir	
Gn 51G-4 Setting <i>Pickup level</i>	0.005, 0.01 ... 0.995, 1	0.5xIn	
Gn 51G-4 TCC <i>Selects characteristic curve to be IEC or ANSI IDMTL or DTL</i>	DTL, IEC-NI ... 201, 202	IEC-NI	
Gn 51G-4 Time Mult (IEC/ANSI) <i>Time multiplier (applicable to IEC and ANSI curves but not DTL selection)</i>	0.025, 0.05 ... 1.575, 1.6	1	
Gn 51G-4 Delay (DTL) <i>Delay (applicable only when DTL is selected for characteristic)</i>	0, 0.01 ... 19.99, 20	5s	
Gn 51G-4 Min Operate Time <i>Minimum operate time of element.</i>	0, 0.01 ... 19.99, 20	0s	
Gn 51G-4 Additional Time <i>Additional definite time added after characteristic time</i>	0, 0.01 ... 19.99, 20	0s	
Gn 51G-4 Reset <i>Selects between an ANSI decaying reset characteristic or DTL reset</i>	(ANSI) Decaying, 0 ... 59, 60	0s	
Gn 51G-4 VTS Action <i>Selects whether 51G-4 element is blocked or made non-directional when VTS operates</i>	Off, Inhibit, Non-Dir	Off	
Gn 51G-4 Inrush Action <i>Selects if the 51G-4 element is blocked from operating when 2nd Harmonic Inrush Detector operates</i>	Off, Inhibit	Off	

## 2.6.4.5. 50G-1

Description	Range	Default	Setting
Gn 50G-1 Element <i>Selects whether the DTL measured Ground fault element is enabled</i>	Disabled, Enabled	Disabled	
Gn 50G-1 Dir. Control <i>Selects whether 50G-1 element is non-directional, forward or reverse</i>	Non-Dir, Forward, Reverse	Non-Dir	
Gn 50G-1 Setting <i>Pickup level</i>	0.005, 0.01 ... 24.995, 25	0.5xIn	
Gn 50G-1 Delay <i>Sets operate delay time</i>	0, 0.01 ... 14300, 14400	0s	
Gn 50G-1 VTS Action <i>Selects whether 50G-1 element is blocked or made non-directional when VTS operates</i>	Off, Inhibit, Non-Dir	Off	
Gn 50G-1 Inrush Action <i>Selects if the 50G-1 element is blocked from operating when 2nd Harmonic Inrush Detector operates</i>	Off, Inhibit	Off	

## 2.6.4.6. 50G-2

Description	Range	Default	Setting
Gn 50G-2 Element <i>Selects whether the DTL measured Ground fault element is enabled</i>	Disabled, Enabled	Disabled	
Gn 50G-2 Dir. Control <i>Selects whether 50G-2 element is non-directional, forward or reverse</i>	Non-Dir, Forward, Reverse	Non-Dir	
Gn 50G-2 Setting <i>Pickup level</i>	0.005, 0.01 ... 24.995, 25	0.5xIn	
Gn 50G-2 Delay <i>Sets operate delay time</i>	0, 0.01 ... 14300, 14400	0s	
Gn 50G-2 VTS Action <i>Selects whether 50G-2 element is blocked or made non-directional when VTS operates</i>	Off, Inhibit, Non-Dir	Off	
Gn 50G-2 Inrush Action <i>Selects if the 50G-2 element is blocked from operating when 2nd Harmonic Inrush Detector operates</i>	Off, Inhibit	Off	

## 2.6.4.7. 50G-3

Description	Range	Default	Setting
Gn 50G-3 Element <i>Selects whether the DTL measured Ground fault element is enabled</i>	Disabled, Enabled	Disabled	
Gn 50G-3 Dir. Control <i>Selects whether 50G-3 element is non-directional, forward or reverse</i>	Non-Dir, Forward, Reverse	Non-Dir	
Gn 50G-3 Setting <i>Pickup level</i>	0.005, 0.01 ... 24.995, 25	0.5xIn	
Gn 50G-3 Delay <i>Sets operate delay time</i>	0, 0.01 ... 14300, 14400	0s	
Gn 50G-3 VTS Action <i>Selects whether 50G-3 element is blocked or made non-directional when VTS operates</i>	Off, Inhibit, Non-Dir	Off	
Gn 50G-3 Inrush Action <i>Selects if the 50G-3 element is blocked from operating when 2nd Harmonic Inrush Detector operates</i>	Off, Inhibit	Off	

## 2.6.4.8. 50G-4

Description	Range	Default	Setting
Gn 50G-4 Element <i>Selects whether the DTL measured Ground fault element is enabled</i>	Disabled, Enabled	Disabled	
Gn 50G-4 Dir. Control <i>Selects whether 50G-4 element is non-directional, forward or reverse</i>	Non-Dir, Forward, Reverse	Non-Dir	
Gn 50G-4 Setting <i>Pickup level</i>	0.005, 0.01 ... 24.995, 25	0.5xIn	

Description	Range	Default	Setting
Gn 50G-4 Delay <i>Sets operate delay time</i>	0, 0.01 ... 14300, 14400	0s	
Gn 50G-4 VTS Action <i>Selects whether 50G-4 element is blocked or made non-directional when VTS operates</i>	Off, Inhibit, Non-Dir	Off	
Gn 50G-4 Inrush Action <i>Selects if the 50G-4 element is blocked from operating when 2nd Harmonic Inrush Detector operates</i>	Off, Inhibit	Off	

## 2.6.5. Sensitive G/F

Description	Range	Default	Setting
Gn 67SGF Char Angle <i>Maximum torque angle for sensitive ground fault elements</i>	-95, -94 ... 94, 95	-15deg	
Gn 67SGF Minimum Voltage <i>Selects the directional elements minimum voltage, below which the element will be inhibited</i>	0.33, 0.5, 1, 1.5, 2, 2.5, 3	0.33V	

## 2.6.5.1. 51SGF-1

Description	Range	Default	Setting
Gn 51SGF-1 Element <i>Selects whether the 51SGF-1 IDMTL derived Ground Fault element is enabled</i>	Disabled, Enabled	Disabled	
Gn 51SGF-1 Dir. Control <i>Selects whether 51SGF-1 element is non-directional, forward or reverse</i>	Non-Dir, Forward, Reverse	Non-Dir	
Gn 51SGF-1 Setting <i>Pickup level</i>	0.005, 0.01 ... 0.995, 1	0.2xIn	
Gn 51SGF-1 TCC <i>Selects characteristic curve to be IEC or ANSI IDMTL or DTL</i>	DTL, IEC-NI ... 201, 202	IEC-NI	
Gn 51SGF-1 Time Mult (IEC/ANSI) <i>Time multiplier (applicable to IEC and ANSI curves but not DTL selection)</i>	0.025, 0.05 ... 1.575, 1.6	1	
Gn 51SGF-1 Delay (DTL) <i>Delay (applicable only when DTL is selected for characteristic)</i>	0, 0.01 ... 19.99, 20	5s	
Gn 51SGF-1 Min Operate Time <i>Minimum operate time of element.</i>	0, 0.01 ... 19.99, 20	0s	
Gn 51SGF-1 Additional Time <i>Additional definite time added after characteristic time</i>	0, 0.01 ... 19.99, 20	0s	
Gn 51SGF-1 Reset <i>Selects between an ANSI decaying reset characteristic or DTL reset</i>	(ANSI) Decaying, 0 ... 59, 60	0s	
Gn 51SGF-1 VTS Action <i>Selects whether 51SGF-1 element is blocked or made non-directional when VTS operates</i>	Off, Inhibit, Non-Dir	Off	

## 2.6.5.2. 51SGF-2

Description	Range	Default	Setting
Gn 51SGF-2 Element <i>Selects whether the 51SGF-2 IDMTL derived Ground Fault element is enabled</i>	Disabled, Enabled	Disabled	
Gn 51SGF-2 Dir. Control <i>Selects whether 51SGF-2 element is non-directional, forward or reverse</i>	Non-Dir, Forward, Reverse	Non-Dir	
Gn 51SGF-2 Setting <i>Pickup level</i>	0.005, 0.01 ... 0.995, 1	0.2xIn	
Gn 51SGF-2 TCC <i>Selects characteristic curve to be IEC or ANSI IDMTL or DTL</i>	DTL, IEC-NI ... 201, 202	IEC-NI	
Gn 51SGF-2 Time Mult (IEC/ANSI) <i>Time multiplier (applicable to IEC and ANSI curves but not DTL selection)</i>	0.025, 0.05 ... 1.575, 1.6	1	
Gn 51SGF-2 Delay (DTL) <i>Delay (applicable only when DTL is selected for characteristic)</i>	0, 0.01 ... 19.99, 20	5s	
Gn 51SGF-2 Min Operate Time <i>Minimum operate time of element.</i>	0, 0.01 ... 19.99, 20	0s	
Gn 51SGF-2 Additional Time <i>Additional definite time added after characteristic time</i>	0, 0.01 ... 19.99, 20	0s	
Gn 51SGF-2 Reset <i>Selects between an ANSI decaying reset characteristic or DTL reset</i>	(ANSI) Decaying, 0 ... 59, 60	0s	
Gn 51SGF-2 VTS Action <i>Selects whether 51SGF-2 element is blocked or made non-directional when VTS operates</i>	Off, Inhibit, Non-Dir	Off	

## 2.6.5.3. 51SGF-3

Description	Range	Default	Setting
Gn 51SGF-3 Element <i>Selects whether the 51SGF-3 IDMTL derived Ground Fault element is enabled</i>	Disabled, Enabled	Disabled	
Gn 51SGF-3 Dir. Control <i>Selects whether 51SGF-3 element is non-directional, forward or reverse</i>	Non-Dir, Forward, Reverse	Non-Dir	
Gn 51SGF-3 Setting <i>Pickup level</i>	0.005, 0.01 ... 0.995, 1	0.2xIn	
Gn 51SGF-3 TCC <i>Selects characteristic curve to be IEC or ANSI IDMTL or DTL</i>	DTL, IEC-NI ... 201, 202	IEC-NI	
Gn 51SGF-3 Time Mult (IEC/ANSI) <i>Time multiplier (applicable to IEC and ANSI curves but not DTL selection)</i>	0.025, 0.05 ... 1.575, 1.6	1	
Gn 51SGF-3 Delay (DTL) <i>Delay (applicable only when DTL is selected for characteristic)</i>	0, 0.01 ... 19.99, 20	5s	

Description	Range	Default	Setting
Gn 51SGF-3 Min Operate Time <i>Minimum operate time of element.</i>	0, 0.01 ... 19.99, 20	0s	
Gn 51SGF-3 Additional Time <i>Additional definite time added after characteristic time</i>	0, 0.01 ... 19.99, 20	0s	
Gn 51SGF-3 Reset <i>Selects between an ANSI decaying reset characteristic or a definite time reset</i>	(ANSI) Decaying, 0 ... 59, 60	0s	
Gn 51SGF-3 VTS Action <i>Selects whether 51SGF-3 element is blocked or made non-directional when VTS operates</i>	Off, Inhibit, Non-Dir	Off	

## 2.6.5.4. 51SGF-4

Description	Range	Default	Setting
Gn 51SGF-4 Element <i>Selects whether the 51SGF-4 IDMTL derived Ground Fault element is enabled</i>	Disabled, Enabled	Disabled	
Gn 51SGF-4 Dir. Control <i>Selects whether 51SGF-4 element is non-directional, forward or reverse</i>	Non-Dir, Forward, Reverse	Non-Dir	
Gn 51SGF-4 Setting <i>Pickup level</i>	0.005, 0.01 ... 0.995, 1	0.2xIn	
Gn 51SGF-4 TCC <i>Selects characteristic curve to be IEC or ANSI IDMTL or DTL</i>	DTL, IEC-NI ... 201, 202	IEC-NI	
Gn 51SGF-4 Time Mult (IEC/ANSI) <i>Time multiplier (applicable to IEC and ANSI curves but not DTL selection)</i>	0.025, 0.05 ... 1.575, 1.6	1	
Gn 51SGF-4 Delay (DTL) <i>Delay (applicable only when DTL is selected for characteristic)</i>	0, 0.01 ... 19.99, 20	5s	
Gn 51SGF-4 Min Operate Time <i>Minimum operate time of element.</i>	0, 0.01 ... 19.99, 20	0s	
Gn 51SGF-4 Additional Time <i>Additional definite time added after characteristic time</i>	0, 0.01 ... 19.99, 20	0s	
Gn 51SGF-4 Reset <i>Selects between an ANSI decaying reset characteristic or a definite time reset</i>	(ANSI) Decaying, 0 ... 59, 60	0s	
Gn 51SGF-4 VTS Action <i>Selects whether 51SGF-4 element is blocked or made non-directional when VTS operates</i>	Off, Inhibit, Non-Dir	Off	

## 2.6.5.5. 50SGF-1

Description	Range	Default	Setting
Gn 50SGF-1 Element <i>Selects whether the DTL measured Ground fault element is enabled</i>	Disabled, Enabled	Disabled	



Description	Range	Default	Setting
Gn 50SGF-1 Dir. Control <i>Selects whether 50SGF-1 element is non-directional, forward or reverse</i>	Non-Dir, Forward, Reverse	Non-Dir	
Gn 50SGF-1 Setting <i>Pickup level</i>	0.005, 0.01 ... 4.995, 5	0.2xIn	
Gn 50SGF-1 Delay <i>Sets operate delay time</i>	0, 0.01 ... 14300, 14400	0s	
Gn 50SGF-1 VTS Action <i>Selects whether 50SGF-1 element is blocked or made non-directional when VTS operates</i>	Off, Inhibit, Non-Dir	Off	

## 2.6.5.6. 50SGF-2

Description	Range	Default	Setting
Gn 50SGF-2 Element <i>Selects whether the DTL measured Ground fault element is enabled</i>	Disabled, Enabled	Disabled	
Gn 50SGF-2 Dir. Control <i>Selects whether 50SGF-2 element is non-directional, forward or reverse</i>	Non-Dir, Forward, Reverse	Non-Dir	
Gn 50SGF-2 Setting <i>Pickup level</i>	0.005, 0.01 ... 4.995, 5	0.2xIn	
Gn 50SGF-2 Delay <i>Sets operate delay time</i>	0, 0.01 ... 14300, 14400	0s	
Gn 50SGF-2 VTS Action <i>Selects whether 50SGF-2 element is blocked or made non-directional when VTS operates</i>	Off, Inhibit, Non-Dir	Off	

## 2.6.5.7. 50SGF-3

Description	Range	Default	Setting
Gn 50SGF-3 Element <i>Selects whether the DTL measured Ground fault element is enabled</i>	Disabled, Enabled	Disabled	
Gn 50SGF-3 Dir. Control <i>Selects whether 50SGF-3 element is non-directional, forward or reverse</i>	Non-Dir, Forward, Reverse	Non-Dir	
Gn 50SGF-3 Setting <i>Pickup level</i>	0.005, 0.01 ... 4.995, 5	0.2xIn	
Gn 50SGF-3 Delay <i>Sets operate delay time</i>	0, 0.01 ... 14300, 14400	0s	
Gn 50SGF-3 VTS Action <i>Selects whether 50SGF-3 element is blocked or made non-directional when VTS operates</i>	Off, Inhibit, Non-Dir	Off	

## 2.6.5.8. 50SGF-4

Description	Range	Default	Setting
Gn 50SGF-4 Element <i>Selects whether the DTL measured Ground fault element is enabled</i>	Disabled, Enabled	Disabled	

Description	Range	Default	Setting
Gn 50SGF-4 Dir. Control <i>Selects whether 50SGF-4 element is non-directional, forward or reverse</i>	Non-Dir, Forward, Reverse	Non-Dir	
Gn 50SGF-4 Setting <i>Pickup level</i>	0.005, 0.01 ... 4.995, 5	0.2xIn	
Gn 50SGF-4 Delay <i>Sets operate delay time</i>	0, 0.01 ... 14300, 14400	0s	
Gn 50SGF-4 VTS Action <i>Selects whether 50SGF-4 element is blocked or made non-directional when VTS operates</i>	Off, Inhibit, Non-Dir	Off	

## 2.6.6. Restricted G/F

Description	Range	Default	Setting
Gn 64H Element <i>High impedance restricted ground fault current element</i>	Disabled, Enabled	Disabled	
Gn 64H Setting <i>Pickup level</i>	0.005, 0.01 ... 0.945, 0.95	0.2xIn	
Gn 64H Delay <i>Sets operate delay time</i>	0, 0.01 ... 14300, 14400	0s	

## 2.6.7. NPS Overcurrent

## 2.6.7.1. 46IT

Description	Range	Default	Setting
Gn 46IT Element <i>Selects whether the 46IT IDMTL/DTL negative phase sequence current element is enabled</i>	Disabled, Enabled	Disabled	
Gn 46IT Setting <i>Pickup level</i>	0.05, 0.06 ... 2.49, 2.5	0.25xIn	
Gn 46IT TCC <i>Selects characteristic curve to be IEC or ANSI IDMTL or DTL</i>	DTL, IEC-NI, IEC-VI, IEC-EI, IEC-LTI, ANSI-MI, ANSI-VI, ANSI-EI	IEC-NI	
Gn 46IT Time Mult (IEC/ANSI) <i>Time multiplier (applicable to IEC and ANSI curves but not DTL selection)</i>	0.025, 0.05 ... 1.575, 1.6	1	
Gn 46IT Delay (DTL) <i>Delay (applicable only when DTL is selected for characteristic)</i>	0, 0.01 ... 19.99, 20	5s	
Gn 46IT Reset <i>Selects between an ANSI decaying reset characteristic or a definite time reset</i>	(ANSI) Decaying, 0 ... 59, 60	0s	

## 2.6.7.2. 46DT

Description	Range	Default	Setting
Gn 46DT Element <i>Selects whether the 46DT INST/DTL negative sequence current element is enabled</i>	Disabled, Enabled	Disabled	

Description	Range	Default	Setting
Gn 46DT Setting <i>Pickup level</i>	0.05, 0.06 ... 3.99, 4	0.1xIn	
Gn 46DT Delay <i>Sets operate delay time</i>	0, 0.01 ... 14300, 14400	0.02s	

## 2.6.8. Under Current

## 2.6.8.1. 37-1

Description	Range	Default	Setting
Gn 37-1 Element <i>Phase under current element 37-1</i>	Disabled, Enabled	Disabled	
Gn 37-1 Setting <i>Pickup level</i>	0.05, 0.1 ... 4.95, 5	0.25xIn	
Gn 37-1 Delay <i>Sets operate delay time</i>	0, 0.01 ... 14300, 14400	0s	

## 2.6.8.2. 37-2

Description	Range	Default	Setting
Gn 37-2 Element <i>Phase under current element 37-2</i>	Disabled, Enabled	Disabled	
Gn 37-2 Setting <i>Pickup level</i>	0.05, 0.1 ... 4.95, 5	0.25xIn	
Gn 37-2 Delay <i>Sets operate delay time</i>	0, 0.01 ... 14300, 14400	0s	

## 2.6.9. Thermal

Description	Range	Default	Setting
Gn 49 Thermal Overload <i>Selects whether the thermal overload protection element is enabled</i>	Disabled, Enabled	Disabled	
Gn 49 Overload Setting <i>Pickup level</i>	0.1, 0.11 ... 2.99, 3	1.05xIn	
Gn 49 Time Constant <i>Thermal time constant</i>	1, 1.5 ... 999.5, 1000	10m	
Gn 49 Capacity Alarm <i>Selects whether thermal capacity alarm enabled</i>	Disabled, 50 ... 99, 100	Disabled%	
49 Reset Therm State <i>Control that allows thermal state to be manually reset</i>	No, Yes	No	

## 2.7. Voltage Prot'n

### 2.7.1. Phase U/O Voltage

Description	Range	Default	Setting
Gn Voltage Input Mode <i>Selects Ph-Ph or Ph-N voltages for U/V guard element &amp; 27/59 elements operation.</i>	Ph-N, Ph-Ph	Ph-N	
Gn 27/59 U/V Guard Setting <i>Selects voltage level below which the guard element is applied.</i>	1, 1.5 ... 199.5, 200	5V	

#### 2.7.1.1. 27/59-1

Description	Range	Default	Setting
Gn 27/59-1 Element <i>Selects whether the Under/Over voltage element stage 1 is enabled</i>	Disabled, Enabled	Disabled	
Gn 27/59-1 Operation <i>Selects between Undervoltage and Overvoltage pickup for this element</i>	Under, Over	Over	
Gn 27/59-1 Setting <i>Under or over voltage pickup level</i>	5, 5.5 ... 199.5, 200	80V	
Gn 27/59-1 Hysteresis <i>Sets the pickup to dropoff thresholds e.g. 3% on Overlevel picks up above pickup setting and drops off below 97% of setting, 3% on Underlevel picks up below setting and drops off above 103% of setting</i>	0, 0.1 ... 79.9, 80	3%	
Gn 27/59-1 Delay <i>Sets operate delay time</i>	0, 0.01 ... 14300, 14400	0.1s	
Gn 27/59-1 U/V Guarded <i>Selects whether U/V Guard element can block the operation of this element</i>	No, Yes	No	
Gn 27/59-1 VTS Inhibit <i>Selects whether element is blocked or not when VTS operates</i>	No, Yes	No	
Gn 27/59-1 O/P Phases <i>Selects whether element operates for any phase picked up or only when all phases are picked up</i>	Any, All	Any	

#### 2.7.1.2. 27/59-2

Description	Range	Default	Setting
Gn 27/59-2 Element <i>Selects whether the Under/Over voltage element stage 2 is enabled</i>	Disabled, Enabled	Disabled	
Gn 27/59-2 Operation <i>Selects between Undervoltage and Overvoltage pickup for this element</i>	Under, Over	Over	
Gn 27/59-2 Setting <i>Under or over voltage pickup level</i>	5, 5.5 ... 199.5, 200	80V	

Description	Range	Default	Setting
Gn 27/59-2 Hysteresis <i>Sets the pickup to dropoff thresholds e.g. 3% on Overlevel picks up above pickup setting and drops off below 97% of setting, 3% on Underlevel picks up below setting and drops off above 103% of setting</i>	0, 0.1 ... 79.9, 80	3%	
Gn 27/59-2 Delay <i>Sets operate delay time</i>	0, 0.01 ... 14300, 14400	0.1s	
Gn 27/59-2 U/V Guarded <i>Selects whether U/V Guard element can block the operation of this element</i>	No, Yes	No	
Gn 27/59-2 VTS Inhibit <i>Selects whether element is blocked or not when VTS operates</i>	No, Yes	No	
Gn 27/59-2 O/P Phases <i>Selects whether element operates for any phase picked up or only when all phases are picked up</i>	Any, All	Any	

## 2.7.1.3. 27/59-3

Description	Range	Default	Setting
Gn 27/59-3 Element <i>Selects whether the Under/Over voltage element stage 3 is enabled</i>	Disabled, Enabled	Disabled	
Gn 27/59-3 Operation <i>Selects between Undervoltage and Overvoltage pickup for this element</i>	Under, Over	Under	
Gn 27/59-3 Setting <i>Under or over voltage pickup level</i>	5, 5.5 ... 199.5, 200	50V	
Gn 27/59-3 Hysteresis <i>Sets the pickup to dropoff thresholds e.g. 3% on Overlevel picks up above pickup setting and drops off below 97% of setting, 3% on Underlevel picks up below setting and drops off above 103% of setting</i>	0, 0.1 ... 79.9, 80	3%	
Gn 27/59-3 Delay <i>Sets operate delay time</i>	0, 0.01 ... 14300, 14400	0.1s	
Gn 27/59-3 U/V Guarded <i>Selects whether U/V Guard element can block the operation of this element</i>	No, Yes	Yes	
Gn 27/59-3 VTS Inhibit <i>Selects whether element is blocked or not when VTS operates</i>	No, Yes	No	
Gn 27/59-3 O/P Phases <i>Selects whether element operates for any phase picked up or only when all phases are picked up</i>	Any, All	Any	

## 2.7.1.4. 27/59-4

Description	Range	Default	Setting
Gn 27/59-4 Element <i>Selects whether the Under/Over voltage element stage 4 is enabled</i>	Disabled, Enabled	Disabled	

Description	Range	Default	Setting
Gn 27/59-4 Operation <i>Selects between Undervoltage and Overvoltage pickup for this element</i>	Under, Over	Under	
Gn 27/59-4 Setting <i>Under or over voltage pickup level</i>	5, 5.5 ... 199.5, 200	50V	
Gn 27/59-4 Hysteresis <i>Sets the pickup to dropoff thresholds e.g. 3% on Overlevel picks up above pickup setting and drops off below 97% of setting, 3% on Underlevel picks up below setting and drops off above 103% of setting</i>	0, 0.1 ... 79.9, 80	3%	
Gn 27/59-4 Delay <i>Sets operate delay time</i>	0, 0.01 ... 14300, 14400	0.1s	
Gn 27/59-4 U/V Guarded <i>Selects whether U/V Guard element can block the operation of this element</i>	No, Yes	Yes	
Gn 27/59-4 VTS Inhibit <i>Selects whether element is blocked or not when VTS operates</i>	No, Yes	No	
Gn 27/59-4 O/P Phases <i>Selects whether element operates for any phase picked up or only when all phases are picked up</i>	Any, All	Any	

### 2.7.2. Vx U/O Voltage

Description	Range	Default	Setting
Gn Vx 27/59 Element <i>Selects whether the Under/Over voltage element for Vx is enabled</i>	Disabled, Enabled	Disabled	
Gn Vx 27/59 Operation <i>Selects between Undervoltage and Overvoltage pickup for this element</i>	Under, Over	Over	
Gn Vx 27/59 Setting <i>Under or over voltage pickup level</i>	5, 5.5 ... 199.5, 200	80V	
Gn Vx 27/59 Hysteresis <i>Sets the pickup to dropoff thresholds e.g. 3% on Overlevel picks up above pickup setting and drops off below 97% of setting, 3% on Underlevel picks up below setting and drops off above 103% of setting</i>	0, 0.1 ... 79.9, 80	3%	
Gn Vx 27/59 Delay <i>Sets operate delay time</i>	0, 0.01 ... 14300, 14400	0.1s	

### 2.7.3. NPS Overvoltage

#### 2.7.3.1. 47-1

Description	Range	Default	Setting
Gn 47-1 Element <i>Selects whether the definite time NPS overvoltage element is enabled</i>	Disabled, Enabled	Disabled	
Gn 47-1 Setting <i>Pickup level</i>	1, 1.5 ... 89.5, 90	20V	

Description	Range	Default	Setting
Gn 47-1 Hysteresis <i>Sets the pickup to drop-off thresholds e.g. 3% picks up at setting and drops off below 97% of setting</i>	0, 0.1 ... 79.9, 80	3%	
Gn 47-1 Delay <i>Sets operate delay time</i>	0, 0.01 ... 14300, 14400	1s	

## 2.7.3.2. 47-2

Description	Range	Default	Setting
Gn 47-2 Element <i>Selects whether the definite time NPS overvoltage element is enabled</i>	Disabled, Enabled	Disabled	
Gn 47-2 Setting <i>Pickup level</i>	1, 1.5 ... 89.5, 90	20V	
Gn 47-2 Hysteresis <i>Sets the pickup to drop-off thresholds e.g. 3% picks up at setting and drops off below 97% of setting</i>	0, 0.1 ... 79.9, 80	3%	
Gn 47-2 Delay <i>Sets operate delay time</i>	0, 0.01 ... 14300, 14400	0.5s	

## 2.7.4. Neutral Overvoltage

Description	Range	Default	Setting
Gn 59N Voltage Source <i>Selects voltage source between calculated 3V0 (Vn) or measured 3V0 through Vx input</i>	Vn, Vx	Vn	

## 2.7.4.1. 59NIT

Description	Range	Default	Setting
Gn 59NIT Element <i>Selects whether the inverse time neutral over voltage element is enabled</i>	Disabled, Enabled	Disabled	
Gn 59NIT Setting <i>Pickup level</i>	1, 1.5 ... 99.5, 100	5V	
Gn 59NIT TCC <i>Selects characteristic curve to be IDMTL or DTL</i>	DTL, IDMTL	IDMTL	
Gn 59NIT Time Mult (IDMTL) <i>Time multiplier (applicable to IDMTL curve but not DTL selection)</i>	0.1, 0.2 ... 139.5, 140	1	
Gn 59NIT Delay (DTL) <i>Delay (applicable only when DTL is selected for characteristic)</i>	0, 0.01 ... 19.99, 20	5s	
Gn 59NIT Reset <i>Selects between an instantaneous reset characteristic or a definite time reset</i>	(ANSI) Decaying, 0 ... 59, 60	0s	

## 2.7.4.2. 59NDT

Description	Range	Default	Setting
Gn 59NDT Element <i>Selects whether the definite time neutral over voltage element is enabled</i>	Disabled, Enabled	Disabled	
Gn 59NDT Setting <i>Pickup level</i>	1, 1.5 ... 99.5, 100	5V	
Gn 59NDT Delay <i>Sets operate delay time</i>	0, 0.01 ... 14300, 14400	0.01s	

## 2.7.5. U/O Frequency

Description	Range	Default	Setting
Gn 81 U/V Guard Setting <i>Selects voltage level below which the guard element is applied.</i>	5, 5.5 ... 199.5, 200	5V	

## 2.7.5.1. 81-1

Description	Range	Default	Setting
Gn 81-1 Element <i>Selects whether the Under/Over frequency element stage 1 is enabled</i>	Disabled, Enabled	Disabled	
Gn 81-1 Operation <i>Selects between Underfrequency and Overfrequency pickup for this element</i>	Under, Over	Under	
Gn 81-1 Setting <i>Under or over frequency pickup level</i>	40, 40.01 ... 69.98, 69.99	49.5Hz	
Gn 81-1 Hysteresis <i>Sets the pickup to dropoff thresholds e.g. 3% on Overlevel picks up above pickup setting and drops off below 97% of setting, 3% on Underlevel picks up below setting and drops off above 103% of setting</i>	0, 0.1 ... 79.9, 80	0.1%	
Gn 81-1 Delay <i>Sets operate delay time</i>	0, 0.1 ... 14300, 14400	1s	
Gn 81-1 U/V Guarded <i>Selects whether U/V Guard element can block the operation of this element</i>	No, Yes	Yes	

## 2.7.5.2. 81-2

Description	Range	Default	Setting
Gn 81-2 Element <i>Selects whether the Under/Over frequency element stage 2 is enabled</i>	Disabled, Enabled	Disabled	
Gn 81-2 Operation <i>Selects between Underfrequency and Overfrequency pickup for this element</i>	Under, Over	Under	
Gn 81-2 Setting <i>Under or over frequency pickup level</i>	40, 40.01 ... 69.98, 69.99	49Hz	



Description	Range	Default	Setting
Gn 81-2 Hysteresis <i>Sets the pickup to dropoff thresholds e.g. 3% on Overlevel picks up above pickup setting and drops off below 97% of setting, 3% on Underlevel picks up below setting and drops off above 103% of setting</i>	0, 0.1 ... 79.9, 80	0.1%	
Gn 81-2 Delay <i>Sets operate delay time</i>	0, 0.1 ... 14300, 14400	0.8s	
Gn 81-2 U/V Guarded <i>Selects whether U/V Guard element can block the operation of this element</i>	No, Yes	Yes	

## 2.7.5.3. 81-3

Description	Range	Default	Setting
Gn 81-3 Element <i>Selects whether the Under/Over frequency element stage 3 is enabled</i>	Disabled, Enabled	Disabled	
Gn 81-3 Operation <i>Selects between Underfrequency and Overfrequency pickup for this element</i>	Under, Over	Under	
Gn 81-3 Setting <i>Under or over frequency pickup level</i>	40, 40.01 ... 69.98, 69.99	48Hz	
Gn 81-3 Hysteresis <i>Sets the pickup to dropoff thresholds e.g. 3% on Overlevel picks up above pickup setting and drops off below 97% of setting, 3% on Underlevel picks up below setting and drops off above 103% of setting</i>	0, 0.1 ... 79.9, 80	0.1%	
Gn 81-3 Delay <i>Sets operate delay time</i>	0, 0.1 ... 14300, 14400	0.6s	
Gn 81-3 U/V Guarded <i>Selects whether U/V Guard element can block the operation of this element</i>	No, Yes	Yes	

## 2.7.5.4. 81-4

Description	Range	Default	Setting
Gn 81-4 Element <i>Selects whether the Under/Over frequency element stage 4 is enabled</i>	Disabled, Enabled	Disabled	
Gn 81-4 Operation <i>Selects between Underfrequency and Overfrequency pickup for this element</i>	Under, Over	Under	
Gn 81-4 Setting <i>Under or over frequency pickup level</i>	40, 40.01 ... 69.98, 69.99	47.5Hz	
Gn 81-4 Hysteresis <i>Sets the pickup to dropoff thresholds e.g. 3% on Overlevel picks up above pickup setting and drops off below 97% of setting, 3% on Underlevel picks up below setting and drops off above 103% of setting</i>	0, 0.1 ... 79.9, 80	0.1%	
Gn 81-4 Delay <i>Sets operate delay time</i>	0, 0.1 ... 14300, 14400	0.4s	

Description	Range	Default	Setting
Gn 81-4 U/V Guarded <i>Selects whether U/V Guard element can block the operation of this element</i>	No, Yes	Yes	

## 2.8. Supervision

### 2.8.1. CB Fail

Description	Range	Default	Setting
Gn 50BF Element <i>Selects whether the Circuit Breaker Fail element is enabled</i>	Disabled, Enabled	Disabled	
Gn 50BF Setting <i>Breaker Fail Current Pickup level. If the current falls below this level then the CB is deemed to have opened and the element is reset.</i>	0.05, 0.055 ... 1.995, 2	0.2xIn	
Gn 50BF-1 Delay <i>Delay before Circuit Breaker Fail stage 1 operates</i>	0, 5 ... 59995, 60000	60ms	
Gn 50BF-2 Delay <i>Delay before Circuit Breaker Fail stage 2 operates</i>	0, 5 ... 59995, 60000	120ms	

### 2.8.2. VT Supervision

Description	Range	Default	Setting
Gn 60VTS Element <i>Selects whether the VT supervision element is enabled</i>	Disabled, Enabled	Disabled	
Gn 60VTS Component <i>Selects whether NPS or ZPS quantities are used by the VT supervision element</i>	NPS, ZPS	NPS	
Gn 60VTS V <i>Level above which there is a possible 1 or 2 phase VT fuse failure</i>	7, 8 ... 109, 110	7V	
Gn 60VTS I <i>Level above which a 1 or 2 phase fault condition is assumed so VTS inhibited</i>	0.05, 0.1, 0.15, 0.2, 0.25, 0.3, 0.35, 0.4, 0.45, 0.5, 0.55, 0.6, 0.65, 0.7, 0.75, 0.8, 0.85, 0.9, 0.95, 1	0.1xIn	
Gn 60VTS Vpps <i>Level below which there is a possible 3 phase VT fuse failure</i>	1, 2 ... 109, 110	15V	
Gn 60VTS Ipps Load <i>Level current must be above before 3 phase VTS will be issued</i>	0.05, 0.1, 0.15, 0.2, 0.25, 0.3, 0.35, 0.4, 0.45, 0.5, 0.55, 0.6, 0.65, 0.7, 0.75, 0.8, 0.85, 0.9, 0.95, 1	0.1xIn	
Gn 60VTS Ipps Fault <i>Level above which 3 phase fault is assumed so VTS inhibited</i>	0.05, 0.1 ... 19.95, 20	10xIn	
Gn 60VTS Delay <i>Sets operate delay time</i>	0.03, 0.04 ... 14300, 14400	10s	

Description	Range	Default	Setting
Gn 60VTS-X Element <i>Selects whether the VT supervision element is enabled</i>	Disabled, Enabled	Disabled	
Gn 60VTS-X Component <i>Selects whether NPS or ZPS quantities are used by the VT supervision element</i>	NPS, ZPS	NPS	
Gn 60VTS-X V <i>Level above which there is a possible 1 or 2 phase VT fuse failure</i>	7, 8 ... 109, 110	7V	
Gn 60VTS-X I <i>Level above which a 1 or 2 phase fault condition is assumed so VTS inhibited</i>	0.05, 0.1, 0.15, 0.2, 0.25, 0.3, 0.35, 0.4, 0.45, 0.5, 0.55, 0.6, 0.65, 0.7, 0.75, 0.8, 0.85, 0.9, 0.95, 1	0.1xIn	
Gn 60VTS-X Vpps <i>Level below which there is a possible 3 phase VT fuse failure</i>	1, 2 ... 109, 110	15V	
Gn 60VTS-X Ipps Load <i>Level current must be above before 3 phase VTS will be issued</i>	0.05, 0.1, 0.15, 0.2, 0.25, 0.3, 0.35, 0.4, 0.45, 0.5, 0.55, 0.6, 0.65, 0.7, 0.75, 0.8, 0.85, 0.9, 0.95, 1	0.1xIn	
Gn 60VTS-X Ipps Fault <i>Level above which 3 phase fault is assumed so VTS inhibited</i>	0.05, 0.1 ... 19.95, 20	10xIn	
Gn 60VTS-X Delay <i>Sets operate delay time</i>	0.03, 0.04 ... 14300, 14400	10s	

### 2.8.3. CT Supervision

Description	Range	Default	Setting
Gn 60CTS Element <i>Selects whether the CT supervision element is enabled (NPS current in the absence of NPS voltage)</i>	Disabled, Enabled	Disabled	
Gn 60CTS Inps <i>Arm if NPS Current (Inps) is above this level</i>	0.05, 0.1, 0.15, 0.2, 0.25, 0.3, 0.35, 0.4, 0.45, 0.5, 0.55, 0.6, 0.65, 0.7, 0.75, 0.8, 0.85, 0.9, 0.95, 1	0.1xIn	
Gn 60CTS Vnps <i>Inhibit if NPS Voltage (Vnps) is above this level</i>	7, 8 ... 109, 110	10V	
Gn 60CTS Delay <i>CTS Operate delay</i>	0.03, 0.04 ... 14300, 14400	10s	

### 2.8.4. Broken Conductor

Description	Range	Default	Setting
Gn 46BC Element <i>Selects whether the definite time broken conductor element is enabled</i>	Disabled, Enabled	Disabled	
Gn 46BC Setting <i>NPS Current to PPS Current ratio</i>	20, 21 ... 99, 100	20%	
Gn 46BC Delay <i>Sets operate delay time</i>	0.03, 0.04 ... 14300, 14400	20s	

## 2.8.5. Trip CCT Supervision

Description	Range	Default	Setting
Gn 74TCS-1 <i>Selects whether the trip circuit supervision element 74TCS-1 is enabled</i>	Disabled, Enabled	Disabled	
Gn 74TCS-1 Delay <i>Time delay before trip circuit supervision operates</i>	0, 0.02 ... 59.98, 60	0.4s	
Gn 74TCS-2 <i>Selects whether the trip circuit supervision element 74TCS-2 is enabled</i>	Disabled, Enabled	Disabled	
Gn 74TCS-2 Delay <i>Time delay before trip circuit supervision operates</i>	0, 0.02 ... 59.98, 60	0.4s	
Gn 74TCS-3 <i>Selects whether the trip circuit supervision element 74TCS-3 is enabled</i>	Disabled, Enabled	Disabled	
Gn 74TCS-3 Delay <i>Time delay before trip circuit supervision operates</i>	0, 0.02 ... 59.98, 60	0.4s	

## 2.8.6. Inrush Detector

Description	Range	Default	Setting
Gn 81HBL2 Element <i>Selects whether the phase inrush detector 81HBL2 is enabled</i>	Disabled, Enabled	Disabled	
Gn 81HBL2 Bias <i>Selects the bias method used for magnetising inrush. Phase – Segregated, each phase blocks itself. Cross – Blocked, each phase can block the operation of other phases. Sum - Of Squares, each phase blocks itself using the square root of the sum of squares of the 2nd harmonic.</i>	Phase, Cross, Sum	Cross	
Gn 81HBL2 Setting <i>The magnetising inrush detector operates when the 2nd harmonic current exceeds a set percentage of the fundamental current</i>	0.1, 0.11 ... 0.49, 0.5	0.2xl	

## 2.8.7. Battery Test

Description	Range	Default	Setting
Battery Element <i>Selects whether the Battery Element is enabled</i>	Disabled, Enabled	Disabled	
Battery Nominal Voltage <i>Selects battery nominal voltage</i>	24, 30, 48, 110, 220	48V	
Battery Test Rate <i>Frequency of battery tests</i>	Every 12 Hours, Every Day ... Every Nov 1st, Every Dec 1st	Every Month 1st	
Battery Test Time <i>Hour of the day at which test will take place</i>	0, 1 ... 22, 23	12	

Description	Range	Default	Setting
Battery Test Load <i>Load resistance applied during test</i>	2.5, 2.6 ... 99.9, 100	6.8ohms	
Battery Volts Drop <i>Max step change in voltage allowed when test load is applied.</i>	0.5, 0.75, 1, 1.25, 1.5, 1.75, 2, 2.25, 2.5, 2.75, 3, 3.25, 3.5	2.5V	

## 2.8.8. Capacitor Test

Description	Range	Default	Setting
Cap Element <i>Selects whether the Capacitor Element is enabled</i>	Disabled, Enabled	Disabled	
Cap Holdup Time <i>If capacitor test load applied for this time &amp; capacitor is still above test threshold the load test will be classed as a pass.</i>	0, 0.02 ... 9.9, 10	5s	

## 2.8.9. Power Quality

Description	Range	Default	Setting
Gn Voltage Input Mode <i>Selects Ph-Ph or Ph-N voltages elements operation.</i>	Ph-N, Ph-Ph	Ph-N	

## 2.8.9.1. 27SAG

Description	Range	Default	Setting
Gn 27Sag Element <i>Selects whether the 27Sag Element is enabled</i>	Disabled, Enabled	Disabled	
Gn 27Sag SARFI Threshold <i>Percentage of nominal voltage below which 27Sag SARFI is raised.</i>	10, 20, 30, 40, 50, 60, 70, 80, 90	70%	
Gn 27Sag VTS Block <i>Selects whether element is blocked or not when VTS operates</i>	Disabled, Enabled	Disabled	
Gn 27Sag SIARFI Delay <i>Time below which the SIARFI count is incremented.</i>	0, 0.01 ... 55, 60	0.5s	
Gn 27Sag SMARFI Delay <i>Time below which the SMARFI count is incremented, if greater than SIARFI Delay.</i>	0, 0.01 ... 55, 60	5s	
Gn 27Sag STARFI Delay <i>Time below which the STARFI count is incremented, if greater than SMARFI Delay. If voltage dip longer than this time it is classed as an interruption.</i>	0, 0.01 ... 55, 60	60s	

## 2.8.9.2. 59SWELL

Description	Range	Default	Setting
-------------	-------	---------	---------

Description	Range	Default	Setting
Gn 59Swell Element <i>Selects whether the 59Swell Element is enabled</i>	Disabled, Enabled	Disabled	
Gn 59Swell SARFI Threshold <i>Percentage of nominal voltage above which 59 SARFI is raised.</i>	110, 120, 130, 140	120%	
Gn 59Swell SIARFI Delay <i>Time below which the SIARFI count is incremented.</i>	0, 0.01 ... 55, 60	0.5s	
Gn 59Swell SMARFI Delay <i>Time below which the SMARFI count is incremented, if greater than SIARFI Delay.</i>	0, 0.01 ... 55, 60	5s	
Gn 59Swell STARFI Delay <i>Time below which the STARFI count is incremented, if greater than SMARFI Delay.</i>	0, 0.01 ... 55, 60	60s	

## 2.8.10. Demand

Description	Range	Default	Setting
Gn Demand Element <i>Selects whether the Demand Element is enabled</i>	Disabled, Enabled	Disabled	
Gn Demand Reset <i>Reset all Demand values</i>			
Gn Demand Log Time Sync <i>When set to Enabled the Demand update period is determined by the "Data Log Period", in "DATA STORAGE" menu, in place of "Demand Update Period".</i>	Disabled, Enabled	Enabled	
Gn Demand Update Period <i>Determines the Demand calculation update period.</i>	1, 2, 3, 4, 5, 10, 15, 30, 45, 60	5mins	
Gn Demand Window <i>The time window over which the Min, Max and Mean values are calculated</i>	1, 2 ... 23, 24	24hrs	
Gn Demand Window Type <i>Method used to calculate Demand values.</i>	Fixed, Peak	Fixed	

## 2.8.11. Control &amp; Logic

## 2.8.12. Autoreclose Prot'n

Description	Range	Default	Setting
Gn 79 P/F Fast Trips <i>Selects which phase fault protection elements are classed as Fast elements and start an autoreclose sequence. These will be blocked from operating during Delayed autoreclose sequences. See autoreclose section of manual for detail of what elements can cause only Delayed protection to be used.</i>	Combination of ( 51-1, 51-2, 51-3, 51-4, 50-1, 50-2, 50-3, 50-4 )	-----	

Description	Range	Default	Setting
Gn 79 G/F Fast Trips <i>Selects which ground fault protection elements are classed as Fast elements and start an autoreclose sequence. These will be blocked from operating during Delayed autoreclose sequences. See autoreclose section of manual for detail of what elements can cause only Delayed protection to be used.</i>	Combination of ( 51G-1, 51G-2, 51G-3, 51G-4, 50G-1, 50G-2, 50G-3, 50G-4 )	-----	
Gn 79 SGF Fast Trips <i>Selects which sensitive ground fault protection elements are classed as Fast elements and start an autoreclose sequence. These will be blocked from operating during Delayed autoreclose sequences. See autoreclose section of manual for detail of what elements can cause only Delayed protection to be used.</i>	Combination of ( 51SGF-1, 51SGF-2, 51SGF-3, 51SGF-4, 50SGF-1, 50SGF-2, 50SGF-3, 50SGF-4 )	-----	
Gn 79 P/F Delayed Trips <i>Selects which phase fault protection are classed as Delayed elements, any selected elements operating will start an autoreclose sequence.</i>	Combination of ( 51-1, 51-2, 51-3, 51-4, 50-1, 50-2, 50-3, 50-4 )	51-1, 51-2, 51-3, 51-4, 50-1, 50-2, 50-3, 50-4	
Gn 79 G/F Delayed Trips <i>Selects which ground fault protection are classed as Delayed elements, any selected elements operating will start an autoreclose sequence.</i>	Combination of ( 51G-1, 51G-2, 51G-3, 51G-4, 50G-1, 50G-2, 50G-3, 50G-4 )	51G-1, 51G-2, 51G-3, 51G-4, 50G-1, 50G-2, 50G-3, 50G-4	
Gn 79 SGF Delayed Trips <i>Selects which sensitive ground fault elements are classed as Delayed elements, any selected elements operating will start an autoreclose sequence.</i>	Combination of ( 51SGF-1, 51SGF-2, 51SGF-3, 51SGF-4, 50SGF-1, 50SGF-2, 50SGF-3, 50SGF-4 )	51SGF-1, 51SGF-2, 51SGF-3, 51SGF-4, 50SGF-1, 50SGF-2, 50SGF-3, 50SGF-4	
Gn 79 P/F HS Trips <i>Selects which phase fault elements are classed as High Set elements, any selected elements operating will start an autoreclose sequence.</i>	Combination of ( 50-1, 50-2, 50-3, 50-4 )	----	
Gn 79 G/F HS Trips <i>Selects which ground fault elements are classed as High Set elements, any selected elements operating will start an autoreclose sequence.</i>	Combination of ( 50G-1, 50G-2, 50G-3, 50G-4 )	----	

## 2.8.13. Autoreclose Config

Description	Range	Default	Setting
Gn 79 Autoreclose <i>If disabled then all attempts to control the AR IN/OUT status will fail and the AR will be permanently Out Of Service. When enabled the AR IN/OUT state may be controlled via the CONTROL MODE menu option, via Binary Input or via local or remote communications.</i>	Disabled, Enabled	Disabled	

<b>Description</b>	<b>Range</b>	<b>Default</b>	<b>Setting</b>
Gn 79 Num Shots <i>Selects the number of auto-reclose attempts before the Autorecloser locks out</i>	1, 2, 3, 4	1	
Gn 79 Retry Enable <i>Selects whether the Retry close functionality is enabled</i>	Disabled, Enabled	Disabled	
Gn 79 Retry Attempts <i>Selects the number of retries allowed per shot</i>	0, 1, 2, 3, 4, 5, 6, 7, 8, 9, 10	1	
Gn 79 Retry Interval <i>Time delay between retries</i>	0, 1 ... 599, 600	60s	
Gn 79 Reclose Blocked Delay <i>Specifies the maximum time that the Autorecloser can be blocked before proceeding to the lockout state. (NOTE: The block delay timer only starts after the Deadtime.)</i>	0, 1 ... 599, 600	60s	
Gn 79 Sequence Fail Timer <i>Time before lockout occurs on an incomplete reclose sequence. (i.e Trip &amp; starter conditions have not been cleared after Sequence Fail Time.)</i>	0, 1 ... 599, 600	60s	
Gn 79 Minimum LO Delay <i>The time after entering lockout before any further external close commands are allowed.</i>	0, 1 ... 599, 600	2s	
Gn 79 Reset LO By Timer <i>Select whether Lockout is automatically reset after a time delay.</i>	Disabled, Enabled	Enabled	
Gn 79 Sequence Co-ord <i>Selects whether Sequence co-ordination functionality is used or not.</i>	Disabled, Enabled	Enabled	
Gn 79 Cold Load Action <i>Selects whether whist Cold Load is active the relay will perform only Delayed Trips or not.</i>	Off, Delayed	Off	

## 2.8.13.1. P/F Shots

<b>Description</b>	<b>Range</b>	<b>Default</b>	<b>Setting</b>
Gn 79 P/F Prot'n Trip 1 <i>Selects whether the first phase fault trip is Fast or Delayed. When set to Delayed all P/F Fast Trips will be Inhibited for this shot.</i>	Fast, Delayed	Fast	
Gn 79 P/F Deadtime 1 <i>Time period between the fault being cleared and the close pulse being issued</i>	0.08, 0.1 ... 14300, 14400	5s	
Gn 79 P/F Prot'n Trip 2 <i>Selects whether the second phase fault trip is Fast or Delayed. When set to Delayed all P/F Fast Trips will be Inhibited for this shot.</i>	Fast, Delayed	Fast	
Gn 79 P/F Deadtime 2 <i>Time period between the fault being cleared and the close pulse being issued</i>	2, 2.1 ... 14300, 14400	5s	



Description	Range	Default	Setting
Gn 79 P/F Prot'n Trip 3 <i>Selects whether the third phase fault trip is Fast or Delayed. When set to Delayed all P/F Fast Trips will be Inhibited for this shot.</i>	Fast, Delayed	Delayed	
Gn 79 P/F Deadtime 3 <i>Time period between the fault being cleared and the close pulse being issued</i>	2, 2.1 ... 14300, 14400	5s	
Gn 79 P/F Prot'n Trip 4 <i>Selects whether the fourth phase fault trip is Fast or Delayed. When set to Delayed all P/F Fast Trips will be Inhibited for this shot.</i>	Fast, Delayed	Delayed	
Gn 79 P/F Deadtime 4 <i>Time period between the fault being cleared and the close pulse being issued</i>	30, 30.1 ... 14300, 14400	30s	
Gn 79 P/F Prot'n Trip 5 <i>Selects whether the fifth phase fault trip is Fast or Delayed. When set to Delayed all P/F Fast Trips will be Inhibited for this shot.</i>	Fast, Delayed	Delayed	
Gn 79 P/F HS Trips To Lockout <i>Selects how many High Set trips are allowed before going to Lockout</i>	1, 2, 3, 4, 5	5	
Gn 79 P/F Delayed Trips To Lockout <i>Selects how many Delayed trips are allowed before going to Lockout</i>	1, 2, 3, 4, 5	5	

## 2.8.13.2. G/F Shots

Description	Range	Default	Setting
Gn 79 G/F Prot'n Trip 1 <i>Selects whether the first ground fault trip is Fast or Delayed. When set to Delayed all G/F Fast Trips will be Inhibited for this shot.</i>	Fast, Delayed	Fast	
Gn 79 G/F Deadtime 1 <i>Time period between the fault being cleared and the close pulse being issued</i>	0.08, 0.1 ... 14300, 14400	5s	
Gn 79 G/F Prot'n Trip 2 <i>Selects whether the second ground fault trip is Fast or Delayed. When set to Delayed all G/F Fast Trips will be Inhibited for this shot.</i>	Fast, Delayed	Fast	
Gn 79 G/F Deadtime 2 <i>Time period between the fault being cleared and the close pulse being issued</i>	2, 2.1 ... 14300, 14400	5s	
Gn 79 G/F Prot'n Trip 3 <i>Selects whether the third ground fault trip is Fast or Delayed. When set to Delayed all G/F Fast Trips will be Inhibited for this shot.</i>	Fast, Delayed	Delayed	
Gn 79 G/F Deadtime 3 <i>Time period between the fault being cleared and the close pulse being issued</i>	2, 2.1 ... 14300, 14400	5s	
Gn 79 G/F Prot'n Trip 4 <i>Selects whether the fourth ground fault trip is Fast or Delayed. When set to Delayed all G/F Fast Trips will be Inhibited for this shot.</i>	Fast, Delayed	Delayed	

Description	Range	Default	Setting
Gn 79 G/F Dearthime 4 <i>Time period between the fault being cleared and the close pulse being issued</i>	30, 30.1 ... 14300, 14400	30s	
Gn 79 G/F Prot'n Trip 5 <i>Selects whether the fifth ground fault trip is Fast or Delayed. When set to Delayed all G/F Fast Trips will be Inhibited for this shot.</i>	Fast, Delayed	Delayed	
Gn 79 G/F HS Trips To Lockout <i>Selects how many High Set trips are allowed before going to Lockout</i>	1, 2, 3, 4, 5	5	
Gn 79 G/F Delayed Trips To Lockout <i>Selects how many Delayed trips are allowed before going to Lockout</i>	1, 2, 3, 4, 5	5	

## 2.8.13.3. SGF Shots

Description	Range	Default	Setting
Gn 79 SGF Prot'n Trip 1 <i>Selects whether the first sensitive ground fault trip is Fast or Delayed. When set to Delayed all SGF Fast Trips will be Inhibited for this shot.</i>	Fast, Delayed	Fast	
Gn 79 SGF Dearthime 1 <i>Time period between the fault being cleared and the close pulse being issued</i>	0.08, 0.1 ... 14300, 14400	5s	
Gn 79 SGF Prot'n Trip 2 <i>Selects whether the second sensitive ground fault trip is Fast or Delayed. When set to Delayed all SGF Fast Trips will be Inhibited for this shot.</i>	Fast, Delayed	Fast	
Gn 79 SGF Dearthime 2 <i>Time period between the fault being cleared and the close pulse being issued</i>	2, 2.1 ... 14300, 14400	5s	
Gn 79 SGF Prot'n Trip 3 <i>Selects whether the third sensitive ground fault trip is Fast or Delayed. When set to Delayed all SGF Fast Trips will be Inhibited for this shot.</i>	Fast, Delayed	Delayed	
Gn 79 SGF Dearthime 3 <i>Time period between the fault being cleared and the close pulse being issued</i>	2, 2.1 ... 14300, 14400	5s	
Gn 79 SGF Prot'n Trip 4 <i>Selects whether the fourth sensitive ground fault trip is Fast or Delayed. When set to Delayed all SGF Fast Trips will be Inhibited for this shot.</i>	Fast, Delayed	Delayed	
Gn 79 SGF Dearthime 4 <i>Time period between the fault being cleared and the close pulse being issued</i>	30, 30.1 ... 14300, 14400	30s	
Gn 79 SGF Prot'n Trip 5 <i>Selects whether the fifth sensitive ground fault trip is Fast or Delayed. When set to Delayed all SGF Fast Trips will be Inhibited for this shot.</i>	Fast, Delayed	Delayed	

Description	Range	Default	Setting
Gn 79 SGF Delayed Trips To Lockout <i>Selects how many Delayed trips are allowed before going to Lockout</i>	1, 2, 3, 4, 5	5	

## 2.8.13.4. Extern Shots

Description	Range	Default	Setting
Gn 79 Extern Prot'n Trip 1 <i>Selects whether the first external trip is Fast or Delayed</i>	Not Blocked, Blocked	Not Blocked	
Gn 79 Extern Deadtime 1 <i>Time period between the fault being cleared and the close pulse being issued</i>	0.08, 0.1 ... 14300, 14400	5s	
Gn 79 Extern Prot'n Trip 2 <i>Selects whether the second external trip is Fast or Delayed</i>	Not Blocked, Blocked	Not Blocked	
Gn 79 Extern Deadtime 2 <i>Time period between the fault being cleared and the close pulse being issued</i>	2, 2.1 ... 14300, 14400	5s	
Gn 79 Extern Prot'n Trip 3 <i>Selects whether the third external trip is Fast or Delayed</i>	Not Blocked, Blocked	Not Blocked	
Gn 79 Extern Deadtime 3 <i>Time period between the fault being cleared and the close pulse being issued</i>	2, 2.1 ... 14300, 14400	5s	
Gn 79 Extern Prot'n Trip 4 <i>Selects whether the fourth external trip is Fast or Delayed</i>	Not Blocked, Blocked	Not Blocked	
Gn 79 Extern Deadtime 4 <i>Time period between the fault being cleared and the close pulse being issued</i>	30, 30.1 ... 14300, 14400	30s	
Gn 79 Extern Prot'n Trip 5 <i>Selects whether the fifth external trip is Fast or Delayed</i>	Not Blocked, Blocked	Not Blocked	
Gn 79 Extern Trips To Lockout <i>Selects how many external trips are allowed before going to Lockout</i>	1, 2, 3, 4, 5	5	

## 2.8.14. Manual Close

Description	Range	Default	Setting
Gn Line Check Trip <i>Selects whether line check trip is enabled, if enabled no AR sequence initiated</i>	Disabled, Enabled	Enabled	
Gn P/F Line Check Trip <i>Selects whether a phase fault line check trip is Fast or Delayed. When set to Delayed all P/F Fast Trips will be Inhibited for this shot.</i>	Fast, Delayed	Fast	
Gn G/F Line Check Trip <i>Selects whether an ground fault line check trip is Fast or Delayed. When set to Delayed all G/F Fast Trips will be Inhibited for this shot.</i>	Fast, Delayed	Fast	

Description	Range	Default	Setting
Gn SGF Line Check Trip <i>Selects whether a sensitive ground fault line check trip is Fast or Delayed. When set to Delayed all SGF Fast Trips will be Inhibited for this shot.</i>	Fast, Delayed	Fast	
Gn Extern Line Check Trip <i>Selects whether an external line check trip is Fast or Delayed</i>	Not Blocked, Blocked	Not Blocked	

## 2.8.15. Circuit Breaker

Description	Range	Default	Setting
Gn Close CB Delay <i>Delay between a Close CB control being received and the Close CB contacts being operated to allow operator walk away.</i>	0, 1 ... 59900, 60000	10000ms	
Gn Close CB Pulse <i>Specifies the duration of the circuit breaker close pulse</i>	0.1, 0.2 ... 59.9, 60	2s	
Gn Reclaim Timer <i>The period of time after a CB has closed and remained closed before the reclosure is deemed to be successful and the AR is re-initialised. If the CB remains open at the end of the reclaim time then the AR goes to lockout.</i>	0, 1 ... 599, 600	2s	
Gn Blocked Close Delay <i>Selects the maximum time that the manual Close CB may be blocked by interlocking before the command or control is cancelled. The relay will signal "Blocked by Interlocking".</i>	0, 1 ... 599, 600	5s	
Gn Open CB Delay <i>Delay between an Open CB control being received and the Open CB contacts being operated.</i>	0, 1 ... 59900, 60000	10000ms	
Gn Open CB Pulse <i>Selects the maximum time of the Open CB pulse. If the CB is not closed when this timer expires then an alarm will be raised to signify failure to close.</i>	0.1, 0.2, 0.3, 0.4, 0.5, 0.6, 0.7, 0.8, 0.9, 1, 1.1, 1.2, 1.3, 1.4, 1.5, 1.6, 1.7, 1.8, 1.9, 2	1s	
Gn CB Travel Alarm <i>Selects the maximum time that the CB should take to either Open or Close before a failure is recorded.</i>	0.01, 0.02 ... 1.99, 2	1s	
Gn CB Controls Latched <i>Selects whether Binary Input triggers of Close CB and Open CB are latched.</i>	Disabled, Enabled	Enabled	

## 2.8.16. LOV Automation

Description	Range	Default	Setting
Gn LOV-A Live <i>Voltage above which the A Side is classed as Live.</i>	5, 5.5 ... 79.5, 80	50V	

<b>Description</b>	<b>Range</b>	<b>Default</b>	<b>Setting</b>
Gn LOV-A Dead <i>Voltage below which the A Side is classed as Dead.</i>	5, 5.5 ... 79.5, 80	10V	
Gn LOV-X Live <i>Voltage above which the X Side is classed as Live.</i>	5, 5.5 ... 79.5, 80	50V	
Gn LOV-X Dead <i>Voltage below which the X Side is classed as Dead.</i>	5, 5.5 ... 79.5, 80	10V	
Gn LOV Automation <i>Selects whether the LOV Automation Element is enabled</i>	Disabled, Enabled	Disabled	
Gn LOV Plant Device Type <i>Selects the appropriate functionality for the type of device</i>	NOP(TIE), Feeder, Recloser	Recloser	
Gn LOV Primed Time <i>Time that the primed condition has to be present for before the LOV Automation is classed as primed.</i>	0, 1 ... 599, 600	5s	
Gn LOV Recloser Opening <i>Select if a Recloser Type should open after LOV and reclose once voltage is restored or stay closed whilst waiting for voltage to be restored.</i>	Disabled, Enabled	Disabled	
Gn LOV Action Delay <i>After Loss of Voltage for this length of time the LOV action starts. (Recloser &amp; Feeder)</i>	0, 1 ... 599, 600	60s	
Gn LOV-A Action <i>Select whether the NOP is to operate for Loss of voltage on the A Side.</i>	Disabled, Enabled	Enabled	
Gn LOV-A Action Delay <i>After the Loss of Voltage on the A Side for this length of time the LOV action starts. (NOP)</i>	0, 1 ... 599, 600	60s	
Gn LOV-X Action <i>Select whether the NOP is to operate for Loss of voltage on the X Side.</i>	Disabled, Enabled	Enabled	
Gn LOV-X Action Delay <i>After the Loss of Voltage on the X Side for this length of time the LOV action starts. (NOP)</i>	0, 1 ... 599, 600	60s	
Gn LOV Sequence Time <i>Time allowed after LOV Action Delay for a NOP to close and Voltage to reappear.</i>	0, 1 ... 599, 600	60s	
Gn LOV Reclose Delay <i>When "Gn LOV Recloser Opening" is Enabled, the voltage must be re-established for this length of time before the Recloser will close.</i>	0, 1 ... 599, 600	5s	
Gn LOV SOTF Time <i>For this length of time after a recloser has been closed, due to an LOV Automation operation, all Fast protections will be allowed to operate.</i>	0, 1 ... 599, 600	5s	

Description	Range	Default	Setting
Gn LOV Reclaim Time <i>For this length of time after the “Gn LOV SOTF Time” all Fast protections will be inhibited.</i>	0, 1 ... 599, 600	60s	
Gn LOV Memory Time <i>Length of time that NOP will remain primed for after losing voltage on both sides.</i>	0, 1 ... 599, 600	60s	

## 2.8.17. Quick Logic

Description	Range	Default	Setting
Quick Logic <i>Enable or Disable all logic equations</i>	Disabled, Enabled	Disabled	
E1 Equation <i>Enable or Disable logic equation E1</i>	Disabled, Enabled	Disabled	
E1 <i>Specify logic equations of the form En = &lt;Operand&gt;&lt;Operator&gt;&lt;Operand&gt;using the following:0123456789=Digit() = Parenthesis! = NOT operation. = AND operation^ = EXCLUSIVE OR operationE(followed by a digit) = Equation numberF (Followed by a digit) = Function Key numberI(Followed by a digit) = Binary Input numberL(Followed by a digit) = LED numberO(Followed by a digit) = output relay numberV(Followed by a digit) =Virtual Input/Output number.ExamplesMake a function key LED toggle when function key is pressed (requires E1 to drive L11 in output matrix)E1 = F3^L11</i>	(20 Character String)		
E1 Pickup Delay <i>Time before equation output operates, after equation satisfied</i>	0, 0.01 ... 14300, 14400	0s	
E1 Dropoff Delay <i>Time before equation output resets, after equation no longer satisfied</i>	0, 0.01 ... 14300, 14400	0s	
E1 Counter Target <i>Select number of times equation must be satisfied before equation output operates</i>	1, 2 ... 998, 999	1	
E1 Counter Reset Mode <i>Select type of counter reset mode</i>	Off, Multi-shot, Single-shot	Off	
E1 Counter Reset Time <i>Select counter reset time</i>	0, 0.01 ... 14300, 14400	0s	
E2 Equation <i>Enable or Disable logic equation E2</i>	Disabled, Enabled	Disabled	

Description	Range	Default	Setting
E2 Specify logic equations of the form $E_n = \langle \text{Operand} \rangle \langle \text{Operator} \rangle \langle \text{Operand} \rangle$ using the following: 0123456789=Digit() = Parenthesis! = NOT operation. = AND operation ^ = EXCLUSIVE OR operation E (followed by a digit) = Equation number F (Followed by a digit) = Function Key number I (Followed by a digit) = Binary Input number L (Followed by a digit) = LED number O (Followed by a digit) = output relay number V (Followed by a digit) = Virtual Input/Output number. Examples Make a function key LED toggle when function key is pressed (requires E1 to drive L11 in output matrix) $E1 = F3 \wedge L11$	(20 Character String)		
E2 Pickup Delay Time before equation output operates, after equation satisfied	0, 0.01 ... 14300, 14400	0s	
E2 Dropoff Delay Time before equation output resets, after equation no longer satisfied	0, 0.01 ... 14300, 14400	0s	
E2 Counter Target Select number of times equation must be satisfied before equation output operates	1, 2 ... 998, 999	1	
E2 Counter Reset Mode Select type of counter reset mode	Off, Multi-shot, Single-shot	Off	
E2 Counter Reset Time Select counter reset time	0, 0.01 ... 14300, 14400	0s	
E3 Equation Enable or Disable logic equation E3	Disabled, Enabled	Disabled	
E3 Specify logic equations of the form $E_n = \langle \text{Operand} \rangle \langle \text{Operator} \rangle \langle \text{Operand} \rangle$ using the following: 0123456789=Digit() = Parenthesis! = NOT operation. = AND operation ^ = EXCLUSIVE OR operation E (followed by a digit) = Equation number F (Followed by a digit) = Function Key number I (Followed by a digit) = Binary Input number L (Followed by a digit) = LED number O (Followed by a digit) = output relay number V (Followed by a digit) = Virtual Input/Output number. Examples Make a function key LED toggle when function key is pressed (requires E1 to drive L11 in output matrix) $E1 = F3 \wedge L11$	(20 Character String)		
E3 Pickup Delay Time before equation output operates, after equation satisfied	0, 0.01 ... 14300, 14400	0s	
E3 Dropoff Delay Time before equation output resets, after equation no longer satisfied	0, 0.01 ... 14300, 14400	0s	
E3 Counter Target Select number of times equation must be satisfied before equation output operates	1, 2 ... 998, 999	1	

Description	Range	Default	Setting
E3 Counter Reset Mode <i>Select type of counter reset mode</i>	Off, Multi-shot, Single-shot	Off	
E3 Counter Reset Time <i>Select counter reset time</i>	0, 0.01 ... 14300, 14400	0s	
E4 Equation <i>Enable or Disable logic equation E4</i>	Disabled, Enabled	Disabled	
E4 <i>Specify logic equations of the form En = &lt;Operand&gt;&lt;Operator&gt;&lt;Operand&gt;using the following:0123456789=Digit() = Parenthesis! = NOT operation. = AND operation^ = EXCLUSIVE OR operationE(followed by a digit) = Equation numberF (Followed by a digit) = Function Key numberI(Followed by a digit) = Binary Input numberL(Followed by a digit) = LED numberO(Followed by a digit) = output relay numberV(Followed by a digit) =Virtual Input/Output number.ExamplesMake a function key LED toggle when function key is pressed (requires E1 to drive L11 in output matrix)E1 = F3^L11</i>	(20 Character String)		
E4 Pickup Delay <i>Time before equation output operates, after equation satisfied</i>	0, 0.01 ... 14300, 14400	0s	
E4 Dropoff Delay <i>Time before equation output resets, after equation no longer satisfied</i>	0, 0.01 ... 14300, 14400	0s	
E4 Counter Target <i>Select number of times equation must be satisfied before equation output operates</i>	1, 2 ... 998, 999	1	
E4 Counter Reset Mode <i>Select type of counter reset mode</i>	Off, Multi-shot, Single-shot	Off	
E4 Counter Reset Time <i>Select counter reset time</i>	0, 0.01 ... 14300, 14400	0s	
E5 Equation <i>Enable or Disable logic equation E5</i>	Disabled, Enabled	Disabled	
E5 <i>Specify logic equations of the form En = &lt;Operand&gt;&lt;Operator&gt;&lt;Operand&gt;using the following:0123456789=Digit() = Parenthesis! = NOT operation. = AND operation^ = EXCLUSIVE OR operationE(followed by a digit) = Equation numberF (Followed by a digit) = Function Key numberI(Followed by a digit) = Binary Input numberL(Followed by a digit) = LED numberO(Followed by a digit) = output relay numberV(Followed by a digit) =Virtual Input/Output number.ExamplesMake a function key LED toggle when function key is pressed (requires E1 to drive L11 in output matrix)E1 = F3^L11</i>	(20 Character String)		
E5 Pickup Delay <i>Time before equation output operates, after equation satisfied</i>	0, 0.01 ... 14300, 14400	0s	



Description	Range	Default	Setting
E5 Dropoff Delay <i>Time before equation output resets, after equation no longer satisfied</i>	0, 0.01 ... 14300, 14400	0s	
E5 Counter Target <i>Select number of times equation must be satisfied before equation output operates</i>	1, 2 ... 998, 999	1	
E5 Counter Reset Mode <i>Select type of counter reset mode</i>	Off, Multi-shot, Single-shot	Off	
E5 Counter Reset Time <i>Select counter reset time</i>	0, 0.01 ... 14300, 14400	0s	
E6 Equation <i>Enable or Disable logic equation E6</i>	Disabled, Enabled	Disabled	
E6 <i>Specify logic equations of the form En = &lt;Operand&gt;&lt;Operator&gt;&lt;Operand&gt; using the following: 0123456789=Digit() = Parenthesis! = NOT operation. = AND operation ^ = EXCLUSIVE OR operation E (followed by a digit) = Equation number F (Followed by a digit) = Function Key number I (Followed by a digit) = Binary Input number L (Followed by a digit) = LED number O (Followed by a digit) = output relay number V (Followed by a digit) = Virtual Input/Output number. Examples Make a function key LED toggle when function key is pressed (requires E1 to drive L11 in output matrix) E1 = F3^L11</i>	(20 Character String)		
E6 Pickup Delay <i>Time before equation output operates, after equation satisfied</i>	0, 0.01 ... 14300, 14400	0s	
E6 Dropoff Delay <i>Time before equation output resets, after equation no longer satisfied</i>	0, 0.01 ... 14300, 14400	0s	
E6 Counter Target <i>Select number of times equation must be satisfied before equation output operates</i>	1, 2 ... 998, 999	1	
E6 Counter Reset Mode <i>Select type of counter reset mode</i>	Off, Multi-shot, Single-shot	Off	
E6 Counter Reset Time <i>Select counter reset time</i>	0, 0.01 ... 14300, 14400	0s	
E7 Equation <i>Enable or Disable logic equation E7</i>	Disabled, Enabled	Disabled	

Description	Range	Default	Setting
E7 Specify logic equations of the form $E_n = \langle \text{Operand} \rangle \langle \text{Operator} \rangle \langle \text{Operand} \rangle$ using the following: 0123456789=Digit() = Parenthesis! = NOT operation. = AND operation ^ = EXCLUSIVE OR operation E (followed by a digit) = Equation number F (Followed by a digit) = Function Key number I (Followed by a digit) = Binary Input number L (Followed by a digit) = LED number O (Followed by a digit) = output relay number V (Followed by a digit) = Virtual Input/Output number. Examples Make a function key LED toggle when function key is pressed (requires E1 to drive L11 in output matrix) $E1 = F3 \wedge L11$	(20 Character String)		
E7 Pickup Delay Time before equation output operates, after equation satisfied	0, 0.01 ... 14300, 14400	0s	
E7 Dropoff Delay Time before equation output resets, after equation no longer satisfied	0, 0.01 ... 14300, 14400	0s	
E7 Counter Target Select number of times equation must be satisfied before equation output operates	1, 2 ... 998, 999	1	
E7 Counter Reset Mode Select type of counter reset mode	Off, Multi-shot, Single-shot	Off	
E7 Counter Reset Time Select counter reset time	0, 0.01 ... 14300, 14400	0s	
E8 Equation Enable or Disable logic equation E8	Disabled, Enabled	Disabled	
E8 Specify logic equations of the form $E_n = \langle \text{Operand} \rangle \langle \text{Operator} \rangle \langle \text{Operand} \rangle$ using the following: 0123456789=Digit() = Parenthesis! = NOT operation. = AND operation ^ = EXCLUSIVE OR operation E (followed by a digit) = Equation number F (Followed by a digit) = Function Key number I (Followed by a digit) = Binary Input number L (Followed by a digit) = LED number O (Followed by a digit) = output relay number V (Followed by a digit) = Virtual Input/Output number. Examples Make a function key LED toggle when function key is pressed (requires E1 to drive L11 in output matrix) $E1 = F3 \wedge L11$	(20 Character String)		
E8 Pickup Delay Time before equation output operates, after equation satisfied	0, 0.01 ... 14300, 14400	0s	
E8 Dropoff Delay Time before equation output resets, after equation no longer satisfied	0, 0.01 ... 14300, 14400	0s	
E8 Counter Target Select number of times equation must be satisfied before equation output operates	1, 2 ... 998, 999	1	

Description	Range	Default	Setting
E8 Counter Reset Mode <i>Select type of counter reset mode</i>	Off, Multi-shot, Single-shot	Off	
E8 Counter Reset Time <i>Select counter reset time</i>	0, 0.01 ... 14300, 14400	0s	
E9 Equation <i>Enable or Disable logic equation E9</i>	Disabled, Enabled	Disabled	
E9 <i>Specify logic equations of the form En = &lt;Operand&gt;&lt;Operator&gt;&lt;Operand&gt;using the following:0123456789=Digit() = Parenthesis! = NOT operation. = AND operation^ = EXCLUSIVE OR operationE(followed by a digit) = Equation numberF (Followed by a digit) = Function Key numberI(Followed by a digit) = Binary Input numberL(Followed by a digit) = LED numberO(Followed by a digit) = output relay numberV(Followed by a digit) =Virtual Input/Output number.ExamplesMake a function key LED toggle when function key is pressed (requires E1 to drive L11 in output matrix)E1 = F3^L11</i>	(20 Character String)		
E9 Pickup Delay <i>Time before equation output operates, after equation satisfied</i>	0, 0.01 ... 14300, 14400	0s	
E9 Dropoff Delay <i>Time before equation output resets, after equation no longer satisfied</i>	0, 0.01 ... 14300, 14400	0s	
E9 Counter Target <i>Select number of times equation must be satisfied before equation output operates</i>	1, 2 ... 998, 999	1	
E9 Counter Reset Mode <i>Select type of counter reset mode</i>	Off, Multi-shot, Single-shot	Off	
E9 Counter Reset Time <i>Select counter reset time</i>	0, 0.01 ... 14300, 14400	0s	
E10 Equation <i>Enable or Disable logic equation E10</i>	Disabled, Enabled	Disabled	
E10 <i>Specify logic equations of the form En = &lt;Operand&gt;&lt;Operator&gt;&lt;Operand&gt;using the following:0123456789=Digit() = Parenthesis! = NOT operation. = AND operation^ = EXCLUSIVE OR operationE(followed by a digit) = Equation numberF (Followed by a digit) = Function Key numberI(Followed by a digit) = Binary Input numberL(Followed by a digit) = LED numberO(Followed by a digit) = output relay numberV(Followed by a digit) =Virtual Input/Output number.ExamplesMake a function key LED toggle when function key is pressed (requires E1 to drive L11 in output matrix)E1 = F3^L11</i>	(20 Character String)		
E10 Pickup Delay <i>Time before equation output operates, after equation satisfied</i>	0, 0.01 ... 14300, 14400	0s	

Description	Range	Default	Setting
E10 Dropoff Delay <i>Time before equation output resets, after equation no longer satisfied</i>	0, 0.01 ... 14300, 14400	0s	
E10 Counter Target <i>Select number of times equation must be satisfied before equation output operates</i>	1, 2 ... 998, 999	1	
E10 Counter Reset Mode <i>Select type of counter reset mode</i>	Off, Multi-shot, Single-shot	Off	
E10 Counter Reset Time <i>Select counter reset time</i>	0, 0.01 ... 14300, 14400	0s	
E11 Equation <i>Enable or Disable logic equation E11</i>	Disabled, Enabled	Disabled	
E11 <i>Specify logic equations of the form En = &lt;Operand&gt;&lt;Operator&gt;&lt;Operand&gt; using the following: 0123456789=Digit() = Parenthesis! = NOT operation. = AND operation ^ = EXCLUSIVE OR operation E (followed by a digit) = Equation number F (Followed by a digit) = Function Key number I (Followed by a digit) = Binary Input number L (Followed by a digit) = LED number O (Followed by a digit) = output relay number V (Followed by a digit) = Virtual Input/Output number. Examples Make a function key LED toggle when function key is pressed (requires E1 to drive L11 in output matrix) E1 = F3^L11</i>	(20 Character String)		
E11 Pickup Delay <i>Time before equation output operates, after equation satisfied</i>	0, 0.01 ... 14300, 14400	0s	
E11 Dropoff Delay <i>Time before equation output resets, after equation no longer satisfied</i>	0, 0.01 ... 14300, 14400	0s	
E11 Counter Target <i>Select number of times equation must be satisfied before equation output operates</i>	1, 2 ... 998, 999	1	
E11 Counter Reset Mode <i>Select type of counter reset mode</i>	Off, Multi-shot, Single-shot	Off	
E11 Counter Reset Time <i>Select counter reset time</i>	0, 0.01 ... 14300, 14400	0s	
E12 Equation <i>Enable or Disable logic equation E12</i>	Disabled, Enabled	Disabled	

Description	Range	Default	Setting
E12 Specify logic equations of the form $E_n = \langle \text{Operand} \rangle \langle \text{Operator} \rangle \langle \text{Operand} \rangle$ using the following: 0123456789=Digit() = Parenthesis! = NOT operation. = AND operation ^ = EXCLUSIVE OR operation E (followed by a digit) = Equation number F (Followed by a digit) = Function Key number I (Followed by a digit) = Binary Input number L (Followed by a digit) = LED number O (Followed by a digit) = output relay number V (Followed by a digit) = Virtual Input/Output number. Examples Make a function key LED toggle when function key is pressed (requires E1 to drive L11 in output matrix) $E1 = F3 \wedge L11$	(20 Character String)		
E12 Pickup Delay Time before equation output operates, after equation satisfied	0, 0.01 ... 14300, 14400	0s	
E12 Dropoff Delay Time before equation output resets, after equation no longer satisfied	0, 0.01 ... 14300, 14400	0s	
E12 Counter Target Select number of times equation must be satisfied before equation output operates	1, 2 ... 998, 999	1	
E12 Counter Reset Mode Select type of counter reset mode	Off, Multi-shot, Single-shot	Off	
E12 Counter Reset Time Select counter reset time	0, 0.01 ... 14300, 14400	0s	
E13 Equation Enable or Disable logic equation E13	Disabled, Enabled	Disabled	
E13 Specify logic equations of the form $E_n = \langle \text{Operand} \rangle \langle \text{Operator} \rangle \langle \text{Operand} \rangle$ using the following: 0123456789=Digit() = Parenthesis! = NOT operation. = AND operation ^ = EXCLUSIVE OR operation E (followed by a digit) = Equation number F (Followed by a digit) = Function Key number I (Followed by a digit) = Binary Input number L (Followed by a digit) = LED number O (Followed by a digit) = output relay number V (Followed by a digit) = Virtual Input/Output number. Examples Make a function key LED toggle when function key is pressed (requires E1 to drive L11 in output matrix) $E1 = F3 \wedge L11$	(20 Character String)		
E13 Pickup Delay Time before equation output operates, after equation satisfied	0, 0.01 ... 14300, 14400	0s	
E13 Dropoff Delay Time before equation output resets, after equation no longer satisfied	0, 0.01 ... 14300, 14400	0s	
E13 Counter Target Select number of times equation must be satisfied before equation output operates	1, 2 ... 998, 999	1	

Description	Range	Default	Setting
E13 Counter Reset Mode <i>Select type of counter reset mode</i>	Off, Multi-shot, Single-shot	Off	
E13 Counter Reset Time <i>Select counter reset time</i>	0, 0.01 ... 14300, 14400	0s	
E14 Equation <i>Enable or Disable logic equation E14</i>	Disabled, Enabled	Disabled	
E14 <i>Specify logic equations of the form En = &lt;Operand&gt;&lt;Operator&gt;&lt;Operand&gt;using the following:0123456789=Digit() = Parenthesis! = NOT operation. = AND operation^ = EXCLUSIVE OR operationE(followed by a digit) = Equation numberF (Followed by a digit) = Function Key numberI(Followed by a digit) = Binary Input numberL(Followed by a digit) = LED numberO(Followed by a digit) = output relay numberV(Followed by a digit) =Virtual Input/Output number.ExamplesMake a function key LED toggle when function key is pressed (requires E1 to drive L11 in output matrix)E1 = F3^L11</i>	(20 Character String)		
E14 Pickup Delay <i>Time before equation output operates, after equation satisfied</i>	0, 0.01 ... 14300, 14400	0s	
E14 Dropoff Delay <i>Time before equation output resets, after equation no longer satisfied</i>	0, 0.01 ... 14300, 14400	0s	
E14 Counter Target <i>Select number of times equation must be satisfied before equation output operates</i>	1, 2 ... 998, 999	1	
E14 Counter Reset Mode <i>Select type of counter reset mode</i>	Off, Multi-shot, Single-shot	Off	
E14 Counter Reset Time <i>Select counter reset time</i>	0, 0.01 ... 14300, 14400	0s	
E15 Equation <i>Enable or Disable logic equation E15</i>	Disabled, Enabled	Disabled	
E15 <i>Specify logic equations of the form En = &lt;Operand&gt;&lt;Operator&gt;&lt;Operand&gt;using the following:0123456789=Digit() = Parenthesis! = NOT operation. = AND operation^ = EXCLUSIVE OR operationE(followed by a digit) = Equation numberF (Followed by a digit) = Function Key numberI(Followed by a digit) = Binary Input numberL(Followed by a digit) = LED numberO(Followed by a digit) = output relay numberV(Followed by a digit) =Virtual Input/Output number.ExamplesMake a function key LED toggle when function key is pressed (requires E1 to drive L11 in output matrix)E1 = F3^L11</i>	(20 Character String)		
E15 Pickup Delay <i>Time before equation output operates, after equation satisfied</i>	0, 0.01 ... 14300, 14400	0s	

Description	Range	Default	Setting
E15 Dropoff Delay <i>Time before equation output resets, after equation no longer satisfied</i>	0, 0.01 ... 14300, 14400	0s	
E15 Counter Target <i>Select number of times equation must be satisfied before equation output operates</i>	1, 2 ... 998, 999	1	
E15 Counter Reset Mode <i>Select type of counter reset mode</i>	Off, Multi-shot, Single-shot	Off	
E15 Counter Reset Time <i>Select counter reset time</i>	0, 0.01 ... 14300, 14400	0s	
E16 Equation <i>Enable or Disable logic equation E16</i>	Disabled, Enabled	Disabled	
E16 <i>Specify logic equations of the form En = &lt;Operand&gt;&lt;Operator&gt;&lt;Operand&gt;using the following:0123456789=Digit() = Parenthesis! = NOT operation. = AND operation^ = EXCLUSIVE OR operationE(followed by a digit) = Equation numberF (Followed by a digit) = Function Key numberI(Followed by a digit) = Binary Input numberL(Followed by a digit) = LED numberO(Followed by a digit) = output relay numberV(Followed by a digit) =Virtual Input/Output number.ExamplesMake a function key LED toggle when function key is pressed (requires E1 to drive L11 in output matrix)E1 = F3^L11</i>	(20 Character String)		
E16 Pickup Delay <i>Time before equation output operates, after equation satisfied</i>	0, 0.01 ... 14300, 14400	0s	
E16 Dropoff Delay <i>Time before equation output resets, after equation no longer satisfied</i>	0, 0.01 ... 14300, 14400	0s	
E16 Counter Target <i>Select number of times equation must be satisfied before equation output operates</i>	1, 2 ... 998, 999	1	
E16 Counter Reset Mode <i>Select type of counter reset mode</i>	Off, Multi-shot, Single-shot	Off	
E16 Counter Reset Time <i>Select counter reset time</i>	0, 0.01 ... 14300, 14400	0s	

## 2.9. Input Config

### 2.9.1. Input Matrix

Description	Range	Default	Setting
Inhibit 51-1 <i>Selects which inputs inhibit the 51-1 element</i>	Combination of ( BI1, BI2, BI3, BI4, BI5, BI6, BI7, BI8, BI9, BI10, BI11, BI12, BI13, V1, V2, V3, V4, V5, V6, V7, V8, V9, V10, V11, V12, V13, V14, V15, V16 )	----- -----	
Inhibit 51-2 <i>Selects which inputs inhibit the 51-2 element</i>	Combination of ( BI1, BI2, BI3, BI4, BI5, BI6, BI7, BI8, BI9, BI10, BI11, BI12, BI13, V1, V2, V3, V4, V5, V6, V7, V8, V9, V10, V11, V12, V13, V14, V15, V16 )	----- -----	
Inhibit 51-3 <i>Selects which inputs inhibit the 51-3 element</i>	Combination of ( BI1, BI2, BI3, BI4, BI5, BI6, BI7, BI8, BI9, BI10, BI11, BI12, BI13, V1, V2, V3, V4, V5, V6, V7, V8, V9, V10, V11, V12, V13, V14, V15, V16 )	----- -----	
Inhibit 51-4 <i>Selects which inputs inhibit the 51-4 element</i>	Combination of ( BI1, BI2, BI3, BI4, BI5, BI6, BI7, BI8, BI9, BI10, BI11, BI12, BI13, V1, V2, V3, V4, V5, V6, V7, V8, V9, V10, V11, V12, V13, V14, V15, V16 )	----- -----	
Inhibit 50-1 <i>Selects which inputs inhibit the 50-1 element</i>	Combination of ( BI1, BI2, BI3, BI4, BI5, BI6, BI7, BI8, BI9, BI10, BI11, BI12, BI13, V1, V2, V3, V4, V5, V6, V7, V8, V9, V10, V11, V12, V13, V14, V15, V16 )	----- -----	
Inhibit 50-2 <i>Selects which inputs inhibit the 50-2 element</i>	Combination of ( BI1, BI2, BI3, BI4, BI5, BI6, BI7, BI8, BI9, BI10, BI11, BI12, BI13, V1, V2, V3, V4, V5, V6, V7, V8, V9, V10, V11, V12, V13, V14, V15, V16 )	----- -----	
Inhibit 50-3 <i>Selects which inputs inhibit the 50-3 element</i>	Combination of ( BI1, BI2, BI3, BI4, BI5, BI6, BI7, BI8, BI9, BI10, BI11, BI12, BI13, V1, V2, V3, V4, V5, V6, V7, V8, V9, V10, V11, V12, V13, V14, V15, V16 )	----- -----	
Inhibit 50-4 <i>Selects which inputs inhibit the 50-4 element</i>	Combination of ( BI1, BI2, BI3, BI4, BI5, BI6, BI7, BI8, BI9, BI10, BI11, BI12, BI13, V1, V2, V3, V4, V5, V6, V7, V8, V9, V10, V11, V12, V13, V14, V15, V16 )	----- -----	
Inhibit 51G-1 <i>Selects which inputs inhibit the 51G-1 element</i>	Combination of ( BI1, BI2, BI3, BI4, BI5, BI6, BI7, BI8, BI9, BI10, BI11, BI12, BI13, V1, V2, V3, V4, V5, V6, V7, V8, V9, V10, V11, V12, V13, V14, V15, V16 )	----- -----	



<b>Description</b>	<b>Range</b>	<b>Default</b>	<b>Setting</b>
Inhibit 51G-2 <i>Selects which inputs inhibit the 51G-2 element</i>	Combination of ( BI1, BI2, BI3, BI4, BI5, BI6, BI7, BI8, BI9, BI10, BI11, BI12, BI13, V1, V2, V3, V4, V5, V6, V7, V8, V9, V10, V11, V12, V13, V14, V15, V16 )	----- -----	
Inhibit 51G-3 <i>Selects which inputs inhibit the 51G-3 element</i>	Combination of ( BI1, BI2, BI3, BI4, BI5, BI6, BI7, BI8, BI9, BI10, BI11, BI12, BI13, V1, V2, V3, V4, V5, V6, V7, V8, V9, V10, V11, V12, V13, V14, V15, V16 )	----- -----	
Inhibit 51G-4 <i>Selects which inputs inhibit the 51G-4 element</i>	Combination of ( BI1, BI2, BI3, BI4, BI5, BI6, BI7, BI8, BI9, BI10, BI11, BI12, BI13, V1, V2, V3, V4, V5, V6, V7, V8, V9, V10, V11, V12, V13, V14, V15, V16 )	----- -----	
Inhibit 50G-1 <i>Selects which inputs inhibit the 50G-1 element</i>	Combination of ( BI1, BI2, BI3, BI4, BI5, BI6, BI7, BI8, BI9, BI10, BI11, BI12, BI13, V1, V2, V3, V4, V5, V6, V7, V8, V9, V10, V11, V12, V13, V14, V15, V16 )	----- -----	
Inhibit 50G-2 <i>Selects which inputs inhibit the 50G-2 element</i>	Combination of ( BI1, BI2, BI3, BI4, BI5, BI6, BI7, BI8, BI9, BI10, BI11, BI12, BI13, V1, V2, V3, V4, V5, V6, V7, V8, V9, V10, V11, V12, V13, V14, V15, V16 )	----- -----	
Inhibit 50G-3 <i>Selects which inputs inhibit the 50G-3 element</i>	Combination of ( BI1, BI2, BI3, BI4, BI5, BI6, BI7, BI8, BI9, BI10, BI11, BI12, BI13, V1, V2, V3, V4, V5, V6, V7, V8, V9, V10, V11, V12, V13, V14, V15, V16 )	----- -----	
Inhibit 50G-4 <i>Selects which inputs inhibit the 50G-4 element</i>	Combination of ( BI1, BI2, BI3, BI4, BI5, BI6, BI7, BI8, BI9, BI10, BI11, BI12, BI13, V1, V2, V3, V4, V5, V6, V7, V8, V9, V10, V11, V12, V13, V14, V15, V16 )	----- -----	
Inhibit 51SGF-1 <i>Selects which inputs inhibit the 51SGF-1 element</i>	Combination of ( BI1, BI2, BI3, BI4, BI5, BI6, BI7, BI8, BI9, BI10, BI11, BI12, BI13, V1, V2, V3, V4, V5, V6, V7, V8, V9, V10, V11, V12, V13, V14, V15, V16 )	----- -----	
Inhibit 51SGF-2 <i>Selects which inputs inhibit the 51SGF-2 element</i>	Combination of ( BI1, BI2, BI3, BI4, BI5, BI6, BI7, BI8, BI9, BI10, BI11, BI12, BI13, V1, V2, V3, V4, V5, V6, V7, V8, V9, V10, V11, V12, V13, V14, V15, V16 )	----- -----	
Inhibit 51SGF-3 <i>Selects which inputs inhibit the 51SGF-3 element</i>	Combination of ( BI1, BI2, BI3, BI4, BI5, BI6, BI7, BI8, BI9, BI10, BI11, BI12, BI13, V1, V2, V3, V4, V5, V6, V7, V8, V9, V10, V11, V12, V13, V14, V15, V16 )	----- -----	

<b>Description</b>	<b>Range</b>	<b>Default</b>	<b>Setting</b>
Inhibit 51SGF-4 <i>Selects which inputs inhibit the 51SGF-4 element</i>	Combination of ( BI1, BI2, BI3, BI4, BI5, BI6, BI7, BI8, BI9, BI10, BI11, BI12, BI13, V1, V2, V3, V4, V5, V6, V7, V8, V9, V10, V11, V12, V13, V14, V15, V16 )	----- -----	
Inhibit 50SGF-1 <i>Selects which inputs inhibit the 50SGF-1 element</i>	Combination of ( BI1, BI2, BI3, BI4, BI5, BI6, BI7, BI8, BI9, BI10, BI11, BI12, BI13, V1, V2, V3, V4, V5, V6, V7, V8, V9, V10, V11, V12, V13, V14, V15, V16 )	----- -----	
Inhibit 50SGF-2 <i>Selects which inputs inhibit the 50SGF-2 element</i>	Combination of ( BI1, BI2, BI3, BI4, BI5, BI6, BI7, BI8, BI9, BI10, BI11, BI12, BI13, V1, V2, V3, V4, V5, V6, V7, V8, V9, V10, V11, V12, V13, V14, V15, V16 )	----- -----	
Inhibit 50SGF-3 <i>Selects which inputs inhibit the 50SGF-3 element</i>	Combination of ( BI1, BI2, BI3, BI4, BI5, BI6, BI7, BI8, BI9, BI10, BI11, BI12, BI13, V1, V2, V3, V4, V5, V6, V7, V8, V9, V10, V11, V12, V13, V14, V15, V16 )	----- -----	
Inhibit 50SGF-4 <i>Selects which inputs inhibit the 50SGF-4 element</i>	Combination of ( BI1, BI2, BI3, BI4, BI5, BI6, BI7, BI8, BI9, BI10, BI11, BI12, BI13, V1, V2, V3, V4, V5, V6, V7, V8, V9, V10, V11, V12, V13, V14, V15, V16 )	----- -----	
Inhibit 64H <i>Selects which inputs inhibit the 64H element</i>	Combination of ( BI1, BI2, BI3, BI4, BI5, BI6, BI7, BI8, BI9, BI10, BI11, BI12, BI13, V1, V2, V3, V4, V5, V6, V7, V8, V9, V10, V11, V12, V13, V14, V15, V16 )	----- -----	
Inhibit 46IT <i>Selects which inputs inhibit the 46IT element</i>	Combination of ( BI1, BI2, BI3, BI4, BI5, BI6, BI7, BI8, BI9, BI10, BI11, BI12, BI13, V1, V2, V3, V4, V5, V6, V7, V8, V9, V10, V11, V12, V13, V14, V15, V16 )	----- -----	
Inhibit 46DT <i>Selects which inputs inhibit the 46DT element</i>	Combination of ( BI1, BI2, BI3, BI4, BI5, BI6, BI7, BI8, BI9, BI10, BI11, BI12, BI13, V1, V2, V3, V4, V5, V6, V7, V8, V9, V10, V11, V12, V13, V14, V15, V16 )	----- -----	
Inhibit 37-1 <i>Selects which inputs inhibit the 37-1 element</i>	Combination of ( BI1, BI2, BI3, BI4, BI5, BI6, BI7, BI8, BI9, BI10, BI11, BI12, BI13, V1, V2, V3, V4, V5, V6, V7, V8, V9, V10, V11, V12, V13, V14, V15, V16 )	----- -----	
Inhibit 37-2 <i>Selects which inputs inhibit the 37-2 element</i>	Combination of ( BI1, BI2, BI3, BI4, BI5, BI6, BI7, BI8, BI9, BI10, BI11, BI12, BI13, V1, V2, V3, V4, V5, V6, V7, V8, V9, V10, V11, V12, V13, V14, V15, V16 )	----- -----	

<b>Description</b>	<b>Range</b>	<b>Default</b>	<b>Setting</b>
Inhibit 49 <i>Selects which inputs inhibit the 49 thermal element</i>	Combination of ( BI1, BI2, BI3, BI4, BI5, BI6, BI7, BI8, BI9, BI10, BI11, BI12, BI13, V1, V2, V3, V4, V5, V6, V7, V8, V9, V10, V11, V12, V13, V14, V15, V16 )	----- -----	
Reset 49 <i>Selects which inputs resets the 49 thermal model element</i>	Combination of ( BI1, BI2, BI3, BI4, BI5, BI6, BI7, BI8, BI9, BI10, BI11, BI12, BI13, V1, V2, V3, V4, V5, V6, V7, V8, V9, V10, V11, V12, V13, V14, V15, V16 )	----- -----	
Inhibit 27/59-1 <i>Selects which inputs inhibit the 27/59-1 element</i>	Combination of ( BI1, BI2, BI3, BI4, BI5, BI6, BI7, BI8, BI9, BI10, BI11, BI12, BI13, V1, V2, V3, V4, V5, V6, V7, V8, V9, V10, V11, V12, V13, V14, V15, V16 )	----- -----	
Inhibit 27/59-2 <i>Selects which inputs inhibit the 27/59-2 element</i>	Combination of ( BI1, BI2, BI3, BI4, BI5, BI6, BI7, BI8, BI9, BI10, BI11, BI12, BI13, V1, V2, V3, V4, V5, V6, V7, V8, V9, V10, V11, V12, V13, V14, V15, V16 )	----- -----	
Inhibit 27/59-3 <i>Selects which inputs inhibit the 27/59-3 element</i>	Combination of ( BI1, BI2, BI3, BI4, BI5, BI6, BI7, BI8, BI9, BI10, BI11, BI12, BI13, V1, V2, V3, V4, V5, V6, V7, V8, V9, V10, V11, V12, V13, V14, V15, V16 )	----- -----	
Inhibit 27/59-4 <i>Selects which inputs inhibit the 27/59-4 element</i>	Combination of ( BI1, BI2, BI3, BI4, BI5, BI6, BI7, BI8, BI9, BI10, BI11, BI12, BI13, V1, V2, V3, V4, V5, V6, V7, V8, V9, V10, V11, V12, V13, V14, V15, V16 )	----- -----	
Inhibit Vx 27/59 <i>Selects which inputs inhibit the Vx 27/59 element</i>	Combination of ( BI1, BI2, BI3, BI4, BI5, BI6, BI7, BI8, BI9, BI10, BI11, BI12, BI13, V1, V2, V3, V4, V5, V6, V7, V8, V9, V10, V11, V12, V13, V14, V15, V16 )	----- -----	
Inhibit 47-1 <i>Selects which inputs inhibit the 47-1 element</i>	Combination of ( BI1, BI2, BI3, BI4, BI5, BI6, BI7, BI8, BI9, BI10, BI11, BI12, BI13, V1, V2, V3, V4, V5, V6, V7, V8, V9, V10, V11, V12, V13, V14, V15, V16 )	----- -----	
Inhibit 47-2 <i>Selects which inputs inhibit the 47-2 element</i>	Combination of ( BI1, BI2, BI3, BI4, BI5, BI6, BI7, BI8, BI9, BI10, BI11, BI12, BI13, V1, V2, V3, V4, V5, V6, V7, V8, V9, V10, V11, V12, V13, V14, V15, V16 )	----- -----	
Inhibit 59NIT <i>Selects which inputs inhibit the 59N IDMTL/DTL element</i>	Combination of ( BI1, BI2, BI3, BI4, BI5, BI6, BI7, BI8, BI9, BI10, BI11, BI12, BI13, V1, V2, V3, V4, V5, V6, V7, V8, V9, V10, V11, V12, V13, V14, V15, V16 )	----- -----	

<b>Description</b>	<b>Range</b>	<b>Default</b>	<b>Setting</b>
Inhibit 59NDT <i>Selects which inputs inhibit the 59N INST/DTL element</i>	Combination of ( BI1, BI2, BI3, BI4, BI5, BI6, BI7, BI8, BI9, BI10, BI11, BI12, BI13, V1, V2, V3, V4, V5, V6, V7, V8, V9, V10, V11, V12, V13, V14, V15, V16 )	----- -----	
Inhibit 81-1 <i>Selects which inputs inhibit the 81-1 element</i>	Combination of ( BI1, BI2, BI3, BI4, BI5, BI6, BI7, BI8, BI9, BI10, BI11, BI12, BI13, V1, V2, V3, V4, V5, V6, V7, V8, V9, V10, V11, V12, V13, V14, V15, V16 )	----- -----	
Inhibit 81-2 <i>Selects which inputs inhibit the 81-2 element</i>	Combination of ( BI1, BI2, BI3, BI4, BI5, BI6, BI7, BI8, BI9, BI10, BI11, BI12, BI13, V1, V2, V3, V4, V5, V6, V7, V8, V9, V10, V11, V12, V13, V14, V15, V16 )	----- -----	
Inhibit 81-3 <i>Selects which inputs inhibit the 81-3 element</i>	Combination of ( BI1, BI2, BI3, BI4, BI5, BI6, BI7, BI8, BI9, BI10, BI11, BI12, BI13, V1, V2, V3, V4, V5, V6, V7, V8, V9, V10, V11, V12, V13, V14, V15, V16 )	----- -----	
Inhibit 81-4 <i>Selects which inputs inhibit the 81-4 element</i>	Combination of ( BI1, BI2, BI3, BI4, BI5, BI6, BI7, BI8, BI9, BI10, BI11, BI12, BI13, V1, V2, V3, V4, V5, V6, V7, V8, V9, V10, V11, V12, V13, V14, V15, V16 )	----- -----	
Inhibit 60CTS <i>Selects which inputs inhibit the CT Supervision element</i>	Combination of ( BI1, BI2, BI3, BI4, BI5, BI6, BI7, BI8, BI9, BI10, BI11, BI12, BI13, V1, V2, V3, V4, V5, V6, V7, V8, V9, V10, V11, V12, V13, V14, V15, V16 )	----- -----	
Inhibit 46BC <i>Selects which inputs inhibit the 46 Broken Conductor element</i>	Combination of ( BI1, BI2, BI3, BI4, BI5, BI6, BI7, BI8, BI9, BI10, BI11, BI12, BI13, V1, V2, V3, V4, V5, V6, V7, V8, V9, V10, V11, V12, V13, V14, V15, V16 )	----- -----	
74TCS-1 <i>Selects which inputs are monitoring trip circuits</i>	Combination of ( BI1, BI2, BI3, BI4, BI5, BI6, BI7, BI8, BI9, BI10, BI11, BI12, BI13, V1, V2, V3, V4, V5, V6, V7, V8, V9, V10, V11, V12, V13, V14, V15, V16 )	----- -----	
74TCS-2 <i>As Above</i>	Combination of ( BI1, BI2, BI3, BI4, BI5, BI6, BI7, BI8, BI9, BI10, BI11, BI12, BI13, V1, V2, V3, V4, V5, V6, V7, V8, V9, V10, V11, V12, V13, V14, V15, V16 )	----- -----	
74TCS-3 <i>As Above</i>	Combination of ( BI1, BI2, BI3, BI4, BI5, BI6, BI7, BI8, BI9, BI10, BI11, BI12, BI13, V1, V2, V3, V4, V5, V6, V7, V8, V9, V10, V11, V12, V13, V14, V15, V16 )	----- -----	

<b>Description</b>	<b>Range</b>	<b>Default</b>	<b>Setting</b>
Inhibit LOV	Combination of ( BI1, BI2, BI3, BI4, BI5, BI6, BI7, BI8, BI9, BI10, BI11, BI12, BI13, V1, V2, V3, V4, V5, V6, V7, V8, V9, V10, V11, V12, V13, V14, V15, V16 )	----- -----	
Trig Trip Contacts <i>Selects which inputs will trigger the Trip contacts</i>	Combination of ( BI1, BI2, BI3, BI4, BI5, BI6, BI7, BI8, BI9, BI10, BI11, BI12, BI13, V1, V2, V3, V4, V5, V6, V7, V8, V9, V10, V11, V12, V13, V14, V15, V16 )	----- -----	
Inhibit 50BF <i>Selects which inputs inhibit the 50BF element</i>	Combination of ( BI1, BI2, BI3, BI4, BI5, BI6, BI7, BI8, BI9, BI10, BI11, BI12, BI13, V1, V2, V3, V4, V5, V6, V7, V8, V9, V10, V11, V12, V13, V14, V15, V16 )	----- -----	
50BF Ext Trip <i>Selects which inputs can also start the 50BF element</i>	Combination of ( BI1, BI2, BI3, BI4, BI5, BI6, BI7, BI8, BI9, BI10, BI11, BI12, BI13, V1, V2, V3, V4, V5, V6, V7, V8, V9, V10, V11, V12, V13, V14, V15, V16 )	----- -----	
Inhibit 60VTS <i>Selects which inputs inhibit the VT Supervision element</i>	Combination of ( BI1, BI2, BI3, BI4, BI5, BI6, BI7, BI8, BI9, BI10, BI11, BI12, BI13, V1, V2, V3, V4, V5, V6, V7, V8, V9, V10, V11, V12, V13, V14, V15, V16 )	----- -----	
Ext Trig 60VTS <i>Selects MCB inputs to VT Supervision element</i>	Combination of ( BI1, BI2, BI3, BI4, BI5, BI6, BI7, BI8, BI9, BI10, BI11, BI12, BI13, V1, V2, V3, V4, V5, V6, V7, V8, V9, V10, V11, V12, V13, V14, V15, V16 )	----- -----	
Ext Reset 60VTS <i>Selects which inputs reset the VT Supervision element</i>	Combination of ( BI1, BI2, BI3, BI4, BI5, BI6, BI7, BI8, BI9, BI10, BI11, BI12, BI13, V1, V2, V3, V4, V5, V6, V7, V8, V9, V10, V11, V12, V13, V14, V15, V16 )	----- -----	
Inhibit 60VTS-X <i>Selects which inputs inhibit the VT Supervision element on the xyz VTs</i>	Combination of ( BI1, BI2, BI3, BI4, BI5, BI6, BI7, BI8, BI9, BI10, BI11, BI12, BI13, V1, V2, V3, V4, V5, V6, V7, V8, V9, V10, V11, V12, V13, V14, V15, V16 )	----- -----	
Ext Trig 60VTS-X <i>Selects MCB inputs to VT Supervision element on the xyz VTs</i>	Combination of ( BI1, BI2, BI3, BI4, BI5, BI6, BI7, BI8, BI9, BI10, BI11, BI12, BI13, V1, V2, V3, V4, V5, V6, V7, V8, V9, V10, V11, V12, V13, V14, V15, V16 )	----- -----	
Ext Reset 60VTS-X <i>Selects which inputs reset the VT Supervision element on the xyz VTs</i>	Combination of ( BI1, BI2, BI3, BI4, BI5, BI6, BI7, BI8, BI9, BI10, BI11, BI12, BI13, V1, V2, V3, V4, V5, V6, V7, V8, V9, V10, V11, V12, V13, V14, V15, V16 )	----- -----	

<b>Description</b>	<b>Range</b>	<b>Default</b>	<b>Setting</b>
Reset CB Total Trip <i>Selects which inputs Reset the CB Total Trip count</i>	Combination of ( BI1, BI2, BI3, BI4, BI5, BI6, BI7, BI8, BI9, BI10, BI11, BI12, BI13, V1, V2, V3, V4, V5, V6, V7, V8, V9, V10, V11, V12, V13, V14, V15, V16 )	----- -----	
Reset CB Delta Trip <i>Selects which inputs Reset the CB Delta Trip count</i>	Combination of ( BI1, BI2, BI3, BI4, BI5, BI6, BI7, BI8, BI9, BI10, BI11, BI12, BI13, V1, V2, V3, V4, V5, V6, V7, V8, V9, V10, V11, V12, V13, V14, V15, V16 )	----- -----	
Reset ARBlock Count <i>Selects which inputs Reset the AR Block count</i>	Combination of ( BI1, BI2, BI3, BI4, BI5, BI6, BI7, BI8, BI9, BI10, BI11, BI12, BI13, V1, V2, V3, V4, V5, V6, V7, V8, V9, V10, V11, V12, V13, V14, V15, V16 )	----- -----	
Reset Freq Ops Count <i>Selects which inputs Reset the Frequent Ops count</i>	Combination of ( BI1, BI2, BI3, BI4, BI5, BI6, BI7, BI8, BI9, BI10, BI11, BI12, BI13, V1, V2, V3, V4, V5, V6, V7, V8, V9, V10, V11, V12, V13, V14, V15, V16 )	----- -----	
Reset CB LO Count <i>Selects which inputs Reset the CB Lockout operations count</i>	Combination of ( BI1, BI2, BI3, BI4, BI5, BI6, BI7, BI8, BI9, BI10, BI11, BI12, BI13, V1, V2, V3, V4, V5, V6, V7, V8, V9, V10, V11, V12, V13, V14, V15, V16 )	----- -----	
Reset I <sup>2</sup> t CB Wear <i>Selects which inputs Reset the I<sup>2</sup>t CB Wear element</i>	Combination of ( BI1, BI2, BI3, BI4, BI5, BI6, BI7, BI8, BI9, BI10, BI11, BI12, BI13, V1, V2, V3, V4, V5, V6, V7, V8, V9, V10, V11, V12, V13, V14, V15, V16 )	----- -----	
Trigger I <sup>2</sup> t CB Wear <i>Selects which inputs will cause an external trigger of the I<sup>2</sup>t CB Wear element</i>	Combination of ( BI1, BI2, BI3, BI4, BI5, BI6, BI7, BI8, BI9, BI10, BI11, BI12, BI13, V1, V2, V3, V4, V5, V6, V7, V8, V9, V10, V11, V12, V13, V14, V15, V16 )	----- -----	
General Alarm 1 <i>Selects which inputs will activate the General Alarm 1 text</i>	Combination of ( BI1, BI2, BI3, BI4, BI5, BI6, BI7, BI8, BI9, BI10, BI11, BI12, BI13, V1, V2, V3, V4, V5, V6, V7, V8, V9, V10, V11, V12, V13, V14, V15, V16 )	----- -----	
General Alarm 2 <i>Selects which inputs will activate the General Alarm 2 text</i>	Combination of ( BI1, BI2, BI3, BI4, BI5, BI6, BI7, BI8, BI9, BI10, BI11, BI12, BI13, V1, V2, V3, V4, V5, V6, V7, V8, V9, V10, V11, V12, V13, V14, V15, V16 )	----- -----	
General Alarm 3 <i>Selects which inputs will activate the General Alarm 3 text</i>	Combination of ( BI1, BI2, BI3, BI4, BI5, BI6, BI7, BI8, BI9, BI10, BI11, BI12, BI13, V1, V2, V3, V4, V5, V6, V7, V8, V9, V10, V11, V12, V13, V14, V15, V16 )	----- -----	

<b>Description</b>	<b>Range</b>	<b>Default</b>	<b>Setting</b>
General Alarm 4 <i>Selects which inputs will activate the General Alarm 4 text</i>	Combination of ( BI1, BI2, BI3, BI4, BI5, BI6, BI7, BI8, BI9, BI10, BI11, BI12, BI13, V1, V2, V3, V4, V5, V6, V7, V8, V9, V10, V11, V12, V13, V14, V15, V16 )	----- -----	
General Alarm 5 <i>Selects which inputs will activate the General Alarm 5 text</i>	Combination of ( BI1, BI2, BI3, BI4, BI5, BI6, BI7, BI8, BI9, BI10, BI11, BI12, BI13, V1, V2, V3, V4, V5, V6, V7, V8, V9, V10, V11, V12, V13, V14, V15, V16 )	----- -----	
General Alarm 6 <i>Selects which inputs will activate the General Alarm 6 text</i>	Combination of ( BI1, BI2, BI3, BI4, BI5, BI6, BI7, BI8, BI9, BI10, BI11, BI12, BI13, V1, V2, V3, V4, V5, V6, V7, V8, V9, V10, V11, V12, V13, V14, V15, V16 )	----- -----	
General Alarm 7 <i>Selects which inputs will activate the General Alarm 7 text</i>	Combination of ( BI1, BI2, BI3, BI4, BI5, BI6, BI7, BI8, BI9, BI10, BI11, BI12, BI13, V1, V2, V3, V4, V5, V6, V7, V8, V9, V10, V11, V12, V13, V14, V15, V16 )	----- -----	
General Alarm 8 <i>Selects which inputs will activate the General Alarm 8 text</i>	Combination of ( BI1, BI2, BI3, BI4, BI5, BI6, BI7, BI8, BI9, BI10, BI11, BI12, BI13, V1, V2, V3, V4, V5, V6, V7, V8, V9, V10, V11, V12, V13, V14, V15, V16 )	----- -----	
General Alarm 9 <i>Selects which inputs will activate the General Alarm 9 text</i>	Combination of ( BI1, BI2, BI3, BI4, BI5, BI6, BI7, BI8, BI9, BI10, BI11, BI12, BI13, V1, V2, V3, V4, V5, V6, V7, V8, V9, V10, V11, V12, V13, V14, V15, V16 )	----- -----	
General Alarm 10 <i>Selects which inputs will activate the General Alarm 10 text</i>	Combination of ( BI1, BI2, BI3, BI4, BI5, BI6, BI7, BI8, BI9, BI10, BI11, BI12, BI13, V1, V2, V3, V4, V5, V6, V7, V8, V9, V10, V11, V12, V13, V14, V15, V16 )	----- -----	
General Alarm 11 <i>Selects which inputs will activate the General Alarm 11 text</i>	Combination of ( BI1, BI2, BI3, BI4, BI5, BI6, BI7, BI8, BI9, BI10, BI11, BI12, BI13, V1, V2, V3, V4, V5, V6, V7, V8, V9, V10, V11, V12, V13, V14, V15, V16 )	----- -----	
General Alarm 12 <i>Selects which inputs will activate the General Alarm 12 text</i>	Combination of ( BI1, BI2, BI3, BI4, BI5, BI6, BI7, BI8, BI9, BI10, BI11, BI12, BI13, V1, V2, V3, V4, V5, V6, V7, V8, V9, V10, V11, V12, V13, V14, V15, V16 )	----- -----	
BatteryTestRequired <i>Selects which inputs will initiate a Battery test</i>	Combination of ( BI1, BI2, BI3, BI4, BI5, BI6, BI7, BI8, BI9, BI10, BI11, BI12, BI13, V1, V2, V3, V4, V5, V6, V7, V8, V9, V10, V11, V12, V13, V14, V15, V16 )	----- -----	

<b>Description</b>	<b>Range</b>	<b>Default</b>	<b>Setting</b>
ExtPowerGood <i>Selects which inputs are used to indicate External power to battery is good.</i>	Combination of ( BI1, BI2, BI3, BI4, BI5, BI6, BI7, BI8, BI9, BI10, BI11, BI12, BI13, V1, V2, V3, V4, V5, V6, V7, V8, V9, V10, V11, V12, V13, V14, V15, V16 )	----- -----	
InhibitBatteryTest <i>Selects which inputs will inhibit a Battery test.</i>	Combination of ( BI1, BI2, BI3, BI4, BI5, BI6, BI7, BI8, BI9, BI10, BI11, BI12, BI13, V1, V2, V3, V4, V5, V6, V7, V8, V9, V10, V11, V12, V13, V14, V15, V16 )	----- -----	
CapMon Input 1 <i>Selects which inputs will monitor Capacitor level 1</i>	Combination of ( BI1, BI2, BI3, BI4, BI5, BI6, BI7, BI8, BI9, BI10, BI11, BI12, BI13, V1, V2, V3, V4, V5, V6, V7, V8, V9, V10, V11, V12, V13, V14, V15, V16 )	----- -----	
CapMon Input 2 <i>Selects which inputs will monitor Capacitor level 2</i>	Combination of ( BI1, BI2, BI3, BI4, BI5, BI6, BI7, BI8, BI9, BI10, BI11, BI12, BI13, V1, V2, V3, V4, V5, V6, V7, V8, V9, V10, V11, V12, V13, V14, V15, V16 )	----- -----	
Capacitor Test <i>Selects which inputs will initiate a Capacitor test.</i>	Combination of ( BI1, BI2, BI3, BI4, BI5, BI6, BI7, BI8, BI9, BI10, BI11, BI12, BI13, V1, V2, V3, V4, V5, V6, V7, V8, V9, V10, V11, V12, V13, V14, V15, V16 )	----- -----	
Inhibit Cap Test <i>Selects which inputs will inhibit a Capacitor test.</i>	Combination of ( BI1, BI2, BI3, BI4, BI5, BI6, BI7, BI8, BI9, BI10, BI11, BI12, BI13, V1, V2, V3, V4, V5, V6, V7, V8, V9, V10, V11, V12, V13, V14, V15, V16 )	----- -----	
Reset SagSwell Count <i>Selects which inputs will reset the 27Sag &amp; 59Swell counts.</i>	Combination of ( BI1, BI2, BI3, BI4, BI5, BI6, BI7, BI8, BI9, BI10, BI11, BI12, BI13, V1, V2, V3, V4, V5, V6, V7, V8, V9, V10, V11, V12, V13, V14, V15, V16 )	----- -----	
Inhibit 27Sag <i>Selects which inputs will inhibit the 27Sag elements</i>	Combination of ( BI1, BI2, BI3, BI4, BI5, BI6, BI7, BI8, BI9, BI10, BI11, BI12, BI13, V1, V2, V3, V4, V5, V6, V7, V8, V9, V10, V11, V12, V13, V14, V15, V16 )	----- -----	
Inhibit 59Swell <i>Selects which inputs will inhibit the 59Swell elements</i>	Combination of ( BI1, BI2, BI3, BI4, BI5, BI6, BI7, BI8, BI9, BI10, BI11, BI12, BI13, V1, V2, V3, V4, V5, V6, V7, V8, V9, V10, V11, V12, V13, V14, V15, V16 )	----- -----	
Reset Demand	Combination of ( BI1, BI2, BI3, BI4, BI5, BI6, BI7, BI8, BI9, BI10, BI11, BI12, BI13, V1, V2, V3, V4, V5, V6, V7, V8, V9, V10, V11, V12, V13, V14, V15, V16 )	----- -----	



Description	Range	Default	Setting
Close CB <i>Selects which inputs will issue a manual close to the circuit breaker.</i>	Combination of ( BI1, BI2, BI3, BI4, BI5, BI6, BI7, BI8, BI9, BI10, BI11, BI12, BI13, V1, V2, V3, V4, V5, V6, V7, V8, V9, V10, V11, V12, V13, V14, V15, V16 )	----- -----	
Block Close CB <i>Selects which inputs will block the manual closing of the circuit breaker.</i>	Combination of ( BI1, BI2, BI3, BI4, BI5, BI6, BI7, BI8, BI9, BI10, BI11, BI12, BI13, V1, V2, V3, V4, V5, V6, V7, V8, V9, V10, V11, V12, V13, V14, V15, V16 )	----- -----	
Open CB <i>Selects which inputs will issue an open to the circuit breaker.</i>	Combination of ( BI1, BI2, BI3, BI4, BI5, BI6, BI7, BI8, BI9, BI10, BI11, BI12, BI13, V1, V2, V3, V4, V5, V6, V7, V8, V9, V10, V11, V12, V13, V14, V15, V16 )	----- -----	
CB Closed <i>Selects which inputs are connected to the circuit breaker closed contacts</i>	Combination of ( BI1, BI2, BI3, BI4, BI5, BI6, BI7, BI8, BI9, BI10, BI11, BI12, BI13, V1, V2, V3, V4, V5, V6, V7, V8, V9, V10, V11, V12, V13, V14, V15, V16 )	----- -----	
CB Open <i>Selects which inputs are connected to the circuit breaker open contacts</i>	Combination of ( BI1, BI2, BI3, BI4, BI5, BI6, BI7, BI8, BI9, BI10, BI11, BI12, BI13, V1, V2, V3, V4, V5, V6, V7, V8, V9, V10, V11, V12, V13, V14, V15, V16 )	----- -----	
79 Out <i>Selects which inputs will switch the Auto-recloser out of service</i>	Combination of ( BI1, BI2, BI3, BI4, BI5, BI6, BI7, BI8, BI9, BI10, BI11, BI12, BI13, V1, V2, V3, V4, V5, V6, V7, V8, V9, V10, V11, V12, V13, V14, V15, V16 )	----- -----	
79 In <i>Selects which inputs will switch the Auto-recloser in service</i>	Combination of ( BI1, BI2, BI3, BI4, BI5, BI6, BI7, BI8, BI9, BI10, BI11, BI12, BI13, V1, V2, V3, V4, V5, V6, V7, V8, V9, V10, V11, V12, V13, V14, V15, V16 )	----- -----	
79 Trip & Reclose <i>Selects which inputs will trigger a trip &amp; reclose</i>	Combination of ( BI1, BI2, BI3, BI4, BI5, BI6, BI7, BI8, BI9, BI10, BI11, BI12, BI13, V1, V2, V3, V4, V5, V6, V7, V8, V9, V10, V11, V12, V13, V14, V15, V16 )	----- -----	
79 Trip & Lockout <i>Selects which inputs will trigger a trip &amp; lockout</i>	Combination of ( BI1, BI2, BI3, BI4, BI5, BI6, BI7, BI8, BI9, BI10, BI11, BI12, BI13, V1, V2, V3, V4, V5, V6, V7, V8, V9, V10, V11, V12, V13, V14, V15, V16 )	----- -----	
79 Ext Trip <i>Selects which input will start an external Auto-reclose sequence</i>	Combination of ( BI1, BI2, BI3, BI4, BI5, BI6, BI7, BI8, BI9, BI10, BI11, BI12, BI13, V1, V2, V3, V4, V5, V6, V7, V8, V9, V10, V11, V12, V13, V14, V15, V16 )	----- -----	

<b>Description</b>	<b>Range</b>	<b>Default</b>	<b>Setting</b>
79 Ext Pickup <i>Selects which input should be connected to the pickup of the external elements required to start an Auto-reclose sequence</i>	Combination of ( BI1, BI2, BI3, BI4, BI5, BI6, BI7, BI8, BI9, BI10, BI11, BI12, BI13, V1, V2, V3, V4, V5, V6, V7, V8, V9, V10, V11, V12, V13, V14, V15, V16 )	----- -----	
79 Block Reclose <i>Selects which inputs will block the Auto-recloser</i>	Combination of ( BI1, BI2, BI3, BI4, BI5, BI6, BI7, BI8, BI9, BI10, BI11, BI12, BI13, V1, V2, V3, V4, V5, V6, V7, V8, V9, V10, V11, V12, V13, V14, V15, V16 )	----- -----	
79 Reset Lockout <i>Selects which inputs will force the Auto-recloser into the Lockout state</i>	Combination of ( BI1, BI2, BI3, BI4, BI5, BI6, BI7, BI8, BI9, BI10, BI11, BI12, BI13, V1, V2, V3, V4, V5, V6, V7, V8, V9, V10, V11, V12, V13, V14, V15, V16 )	----- -----	
79 Line Check <i>Selects which inputs will start the Line Check functionality of the Auto-recloser</i>	Combination of ( BI1, BI2, BI3, BI4, BI5, BI6, BI7, BI8, BI9, BI10, BI11, BI12, BI13, V1, V2, V3, V4, V5, V6, V7, V8, V9, V10, V11, V12, V13, V14, V15, V16 )	----- -----	
79 Lockout <i>Selects which inputs will force the Auto-recloser into the Lockout state</i>	Combination of ( BI1, BI2, BI3, BI4, BI5, BI6, BI7, BI8, BI9, BI10, BI11, BI12, BI13, V1, V2, V3, V4, V5, V6, V7, V8, V9, V10, V11, V12, V13, V14, V15, V16 )	----- -----	
Hot Line Out <i>Selects which inputs will switch out Hot Line Working</i>	Combination of ( BI1, BI2, BI3, BI4, BI5, BI6, BI7, BI8, BI9, BI10, BI11, BI12, BI13, V1, V2, V3, V4, V5, V6, V7, V8, V9, V10, V11, V12, V13, V14, V15, V16 )	----- -----	
Hot Line In <i>Selects which inputs will switch in Hot Line Working</i>	Combination of ( BI1, BI2, BI3, BI4, BI5, BI6, BI7, BI8, BI9, BI10, BI11, BI12, BI13, V1, V2, V3, V4, V5, V6, V7, V8, V9, V10, V11, V12, V13, V14, V15, V16 )	----- -----	
Fast Prot'n Out <i>Selects which inputs will switch out the fast protection elements</i>	Combination of ( BI1, BI2, BI3, BI4, BI5, BI6, BI7, BI8, BI9, BI10, BI11, BI12, BI13, V1, V2, V3, V4, V5, V6, V7, V8, V9, V10, V11, V12, V13, V14, V15, V16 )	----- -----	
Fast Prot'n In <i>Selects which inputs will switch in the fast protection elements</i>	Combination of ( BI1, BI2, BI3, BI4, BI5, BI6, BI7, BI8, BI9, BI10, BI11, BI12, BI13, V1, V2, V3, V4, V5, V6, V7, V8, V9, V10, V11, V12, V13, V14, V15, V16 )	----- -----	
G/F Out <i>Selects which inputs will switch out the G/F protection elements</i>	Combination of ( BI1, BI2, BI3, BI4, BI5, BI6, BI7, BI8, BI9, BI10, BI11, BI12, BI13, V1, V2, V3, V4, V5, V6, V7, V8, V9, V10, V11, V12, V13, V14, V15, V16 )	----- -----	

Description	Range	Default	Setting
G/F In <i>Selects which inputs will switch in the G/F protection elements</i>	Combination of ( BI1, BI2, BI3, BI4, BI5, BI6, BI7, BI8, BI9, BI10, BI11, BI12, BI13, V1, V2, V3, V4, V5, V6, V7, V8, V9, V10, V11, V12, V13, V14, V15, V16 )	----- -----	
SGF Out <i>Selects which inputs will switch out the SGF protection elements</i>	Combination of ( BI1, BI2, BI3, BI4, BI5, BI6, BI7, BI8, BI9, BI10, BI11, BI12, BI13, V1, V2, V3, V4, V5, V6, V7, V8, V9, V10, V11, V12, V13, V14, V15, V16 )	----- -----	
SGF In <i>Selects which inputs will switch in the SGF protection elements</i>	Combination of ( BI1, BI2, BI3, BI4, BI5, BI6, BI7, BI8, BI9, BI10, BI11, BI12, BI13, V1, V2, V3, V4, V5, V6, V7, V8, V9, V10, V11, V12, V13, V14, V15, V16 )	----- -----	
LOV Out <i>Selects which inputs will switch out the LOV Automation.</i>	Combination of ( BI1, BI2, BI3, BI4, BI5, BI6, BI7, BI8, BI9, BI10, BI11, BI12, BI13, V1, V2, V3, V4, V5, V6, V7, V8, V9, V10, V11, V12, V13, V14, V15, V16 )	----- -----	
LOV In <i>Selects which inputs will switch in the LOV Automation.</i>	Combination of ( BI1, BI2, BI3, BI4, BI5, BI6, BI7, BI8, BI9, BI10, BI11, BI12, BI13, V1, V2, V3, V4, V5, V6, V7, V8, V9, V10, V11, V12, V13, V14, V15, V16 )	----- -----	
Trigger Wave Rec <i>Selects which inputs can trigger a waveform record</i>	Combination of ( BI1, BI2, BI3, BI4, BI5, BI6, BI7, BI8, BI9, BI10, BI11, BI12, BI13, V1, V2, V3, V4, V5, V6, V7, V8, V9, V10, V11, V12, V13, V14, V15, V16 )	----- -----	
Trigger Fault Rec <i>Selects which inputs can trigger a fault record</i>	Combination of ( BI1, BI2, BI3, BI4, BI5, BI6, BI7, BI8, BI9, BI10, BI11, BI12, BI13, V1, V2, V3, V4, V5, V6, V7, V8, V9, V10, V11, V12, V13, V14, V15, V16 )	----- -----	
Select Group 1 <i>Switches active setting group to group 1</i>	Combination of ( BI1, BI2, BI3, BI4, BI5, BI6, BI7, BI8, BI9, BI10, BI11, BI12, BI13, V1, V2, V3, V4, V5, V6, V7, V8, V9, V10, V11, V12, V13, V14, V15, V16 )	----- -----	
Select Group 2 <i>Switches active setting group to group 2</i>	Combination of ( BI1, BI2, BI3, BI4, BI5, BI6, BI7, BI8, BI9, BI10, BI11, BI12, BI13, V1, V2, V3, V4, V5, V6, V7, V8, V9, V10, V11, V12, V13, V14, V15, V16 )	----- -----	
Select Group 3 <i>Switches active setting group to group 3</i>	Combination of ( BI1, BI2, BI3, BI4, BI5, BI6, BI7, BI8, BI9, BI10, BI11, BI12, BI13, V1, V2, V3, V4, V5, V6, V7, V8, V9, V10, V11, V12, V13, V14, V15, V16 )	----- -----	

<b>Description</b>	<b>Range</b>	<b>Default</b>	<b>Setting</b>
Select Group 4 <i>Switches active setting group to group 4</i>	Combination of ( BI1, BI2, BI3, BI4, BI5, BI6, BI7, BI8, BI9, BI10, BI11, BI12, BI13, V1, V2, V3, V4, V5, V6, V7, V8, V9, V10, V11, V12, V13, V14, V15, V16 )	----- -----	
Select Group 5 <i>Switches active setting group to group 5</i>	Combination of ( BI1, BI2, BI3, BI4, BI5, BI6, BI7, BI8, BI9, BI10, BI11, BI12, BI13, V1, V2, V3, V4, V5, V6, V7, V8, V9, V10, V11, V12, V13, V14, V15, V16 )	----- -----	
Select Group 6 <i>Switches active setting group to group 6</i>	Combination of ( BI1, BI2, BI3, BI4, BI5, BI6, BI7, BI8, BI9, BI10, BI11, BI12, BI13, V1, V2, V3, V4, V5, V6, V7, V8, V9, V10, V11, V12, V13, V14, V15, V16 )	----- -----	
Select Group 7 <i>Switches active setting group to group 7</i>	Combination of ( BI1, BI2, BI3, BI4, BI5, BI6, BI7, BI8, BI9, BI10, BI11, BI12, BI13, V1, V2, V3, V4, V5, V6, V7, V8, V9, V10, V11, V12, V13, V14, V15, V16 )	----- -----	
Select Group 8 <i>Switches active setting group to group 8</i>	Combination of ( BI1, BI2, BI3, BI4, BI5, BI6, BI7, BI8, BI9, BI10, BI11, BI12, BI13, V1, V2, V3, V4, V5, V6, V7, V8, V9, V10, V11, V12, V13, V14, V15, V16 )	----- -----	
Out Of Service Mode <i>Selects which inputs will put the relay into Out Of Service Mode</i>	Combination of ( BI1, BI2, BI3, BI4, BI5, BI6, BI7, BI8, BI9, BI10, BI11, BI12, BI13, V1, V2, V3, V4, V5, V6, V7, V8, V9, V10, V11, V12, V13, V14, V15, V16 )	----- -----	
Local Mode <i>Selects which inputs will put the relay into Local Mode</i>	Combination of ( BI1, BI2, BI3, BI4, BI5, BI6, BI7, BI8, BI9, BI10, BI11, BI12, BI13, V1, V2, V3, V4, V5, V6, V7, V8, V9, V10, V11, V12, V13, V14, V15, V16 )	----- -----	
Remote Mode <i>Selects which inputs will put the relay into Remote Mode</i>	Combination of ( BI1, BI2, BI3, BI4, BI5, BI6, BI7, BI8, BI9, BI10, BI11, BI12, BI13, V1, V2, V3, V4, V5, V6, V7, V8, V9, V10, V11, V12, V13, V14, V15, V16 )	----- -----	
Local Or Remote Mode <i>Selects which inputs will put the relay into Local Or Remote Mode</i>	Combination of ( BI1, BI2, BI3, BI4, BI5, BI6, BI7, BI8, BI9, BI10, BI11, BI12, BI13, V1, V2, V3, V4, V5, V6, V7, V8, V9, V10, V11, V12, V13, V14, V15, V16 )	----- -----	
Clock Sync. <i>Selects which input is used to synchronise the real time clock</i>	Combination of ( BI1, BI2, BI3, BI4, BI5, BI6, BI7, BI8, BI9, BI10, BI11, BI12, BI13, V1, V2, V3, V4, V5, V6, V7, V8, V9, V10, V11, V12, V13, V14, V15, V16 )	----- -----	

Description	Range	Default	Setting
Reset LEDs & O/Ps <i>Selects which inputs will reset the latched LEDs and binary outputs</i>	Combination of ( BI1, BI2, BI3, BI4, BI5, BI6, BI7, BI8, BI9, BI10, BI11, BI12, BI13, V1, V2, V3, V4, V5, V6, V7, V8, V9, V10, V11, V12, V13, V14, V15, V16 )	----- -----	

## 2.9.2. Function Key Matrix

Description	Range	Default	Setting
Open CB <i>Selects which function key will issue an open to the circuit breaker.</i>	Combination of ( 1, 2, 3, 4, 5, 6 )	-----	
Close CB <i>Selects which function key will issue a close to the circuit breaker.</i>	Combination of ( 1, 2, 3, 4, 5, 6 )	-----	
79 In/Out <i>Selects which function key will toggle Autoreclose In &amp; Out</i>	Combination of ( 1, 2, 3, 4, 5, 6 )	-----	
79 Trip & Reclose <i>Selects which inputs will trigger a trip &amp; reclose</i>	Combination of ( 1, 2, 3, 4, 5, 6 )	-----	
79 Trip & Lockout <i>Selects which inputs will trigger a trip &amp; lockout</i>	Combination of ( 1, 2, 3, 4, 5, 6 )	-----	
Hot Line Work In/Out <i>Selects which function key will toggle Hot Line Working In &amp; Out</i>	Combination of ( 1, 2, 3, 4, 5, 6 )	-----	
G/F In/Out <i>Selects which function key will toggle G/Fprotection In &amp; Out</i>	Combination of ( 1, 2, 3, 4, 5, 6 )	-----	
SGF In/Out <i>Selects which function key will toggle SGF protection In &amp; Out</i>	Combination of ( 1, 2, 3, 4, 5, 6 )	-----	
Fast Prot'n In/Out <i>Selects which function key will toggle Fast protection elements In &amp; Out</i>	Combination of ( 1, 2, 3, 4, 5, 6 )	-----	
LOV In/Out <i>Selects which function key will toggle LOV Automation In &amp; Out</i>	Combination of ( 1, 2, 3, 4, 5, 6, 7, 8, 9, 10, 11, 12 )	-----	
BatteryTestRequired <i>Selects which function key will initiate a battery test sequence.</i>	Combination of ( 1, 2, 3, 4, 5, 6 )	-----	

## 2.9.3. Binary Input Config

Description	Range	Default	Setting
Inverted Inputs <i>Selects which inputs pickup when voltage is removed.</i>	Combination of ( 1, 2, 3, 4, 5, 6, 7, 8, 9, 10, 11, 12, 13 )	-----	
BI 1 Pickup Delay <i>Delay on pickup of DC Binary Input 1</i>	0, 0.005 ... 14300, 14400	0.02s	
BI 1 Dropoff Delay <i>Delay on dropoff of DC Binary Input 1</i>	0, 0.005 ... 14300, 14400	0s	

<b>Description</b>	<b>Range</b>	<b>Default</b>	<b>Setting</b>
BI 2 Pickup Delay <i>Delay on pickup of DC Binary Input 2</i>	0, 0.005 ... 14300, 14400	0.02s	
BI 2 Dropoff Delay <i>Delay on dropoff of DC Binary Input 2</i>	0, 0.005 ... 14300, 14400	0s	
BI 3 Pickup Delay <i>Delay on pickup of DC Binary Input 3</i>	0, 0.005 ... 14300, 14400	0.02s	
BI 3 Dropoff Delay <i>Delay on dropoff of DC Binary Input 3</i>	0, 0.005 ... 14300, 14400	0s	
BI 4 Pickup Delay <i>Delay on pickup of DC Binary Input 4</i>	0, 0.005 ... 14300, 14400	0.02s	
BI 4 Dropoff Delay <i>Delay on dropoff of DC Binary Input 4</i>	0, 0.005 ... 14300, 14400	0s	
BI 5 Pickup Delay <i>Delay on pickup of DC Binary Input 5</i>	0, 0.005 ... 14300, 14400	0.02s	
BI 5 Dropoff Delay <i>Delay on dropoff of DC Binary Input 5</i>	0, 0.005 ... 14300, 14400	0s	
BI 6 Pickup Delay <i>Delay on pickup of DC Binary Input 6</i>	0, 0.005 ... 14300, 14400	0.02s	
BI 6 Dropoff Delay <i>Delay on dropoff of DC Binary Input 6</i>	0, 0.005 ... 14300, 14400	0s	
BI 7 Pickup Delay <i>Delay on pickup of DC Binary Input 7</i>	0, 0.005 ... 14300, 14400	0.02s	
BI 7 Dropoff Delay <i>Delay on dropoff of DC Binary Input 7</i>	0, 0.005 ... 14300, 14400	0s	
BI 8 Pickup Delay <i>Delay on pickup of DC Binary Input 8</i>	0, 0.005 ... 14300, 14400	0.02s	
BI 8 Dropoff Delay <i>Delay on dropoff of DC Binary Input 8</i>	0, 0.005 ... 14300, 14400	0s	
BI 9 Pickup Delay <i>Delay on pickup of DC Binary Input 9</i>	0, 0.005 ... 14300, 14400	0.02s	
BI 9 Dropoff Delay <i>Delay on dropoff of DC Binary Input 9</i>	0, 0.005 ... 14300, 14400	0s	
BI 10 Pickup Delay <i>Delay on pickup of DC Binary Input 10</i>	0, 0.005 ... 14300, 14400	0.02s	
BI 10 Dropoff Delay <i>Delay on dropoff of DC Binary Input 10</i>	0, 0.005 ... 14300, 14400	0s	
BI 11 Pickup Delay <i>Delay on pickup of DC Binary Input 11</i>	0, 0.005 ... 14300, 14400	0.02s	
BI 11 Dropoff Delay <i>Delay on dropoff of DC Binary Input 11</i>	0, 0.005 ... 14300, 14400	0s	
BI 12 Pickup Delay <i>Delay on pickup of DC Binary Input 12</i>	0, 0.005 ... 14300, 14400	0.02s	
BI 12 Dropoff Delay <i>Delay on dropoff of DC Binary Input 12</i>	0, 0.005 ... 14300, 14400	0s	
BI 13 Pickup Delay <i>Delay on pickup of DC Binary Input 13</i>	0, 0.005 ... 14300, 14400	0.02s	
BI 13 Dropoff Delay <i>Delay on dropoff of DC Binary Input 13</i>	0, 0.005 ... 14300, 14400	0s	

## 2.9.4. Function key Config

Description	Range	Default	Setting
Function Key 1 Text <i>User definable text that will be used in the HMI function key confirmation screen when Function key 1 is pressed.</i>	(20 Character String)	Function Key 1	
Function Key 2 Text <i>User definable text that will be used in the HMI function key confirmation screen when Function key 2 is pressed.</i>	(20 Character String)	Function Key 2	
Function Key 3 Text <i>User definable text that will be used in the HMI function key confirmation screen when Function key 3 is pressed.</i>	(20 Character String)	Function Key 3	
Function Key 4 Text <i>User definable text that will be used in the HMI function key confirmation screen when Function key 4 is pressed.</i>	(20 Character String)	Function Key 4	
Function Key 5 Text <i>User definable text that will be used in the HMI function key confirmation screen when Function key 5 is pressed.</i>	(20 Character String)	Function Key 5	
Function Key 6 Text <i>User definable text that will be used in the HMI function key confirmation screen when Function key 6 is pressed.</i>	(20 Character String)	Function Key 6	

## 2.9.5. General Alarms

Description	Range	Default	Setting
General Alarm-1 <i>Defines the text to be displayed for General Alarm 1</i>	(16 Character String)	ALARM 1	
General Alarm-2 <i>Defines the text to be displayed for General Alarm 2</i>	(16 Character String)	ALARM 2	
General Alarm-3 <i>Defines the text to be displayed for General Alarm 3</i>	(16 Character String)	ALARM 3	
General Alarm-4 <i>Defines the text to be displayed for General Alarm 4</i>	(16 Character String)	ALARM 4	
General Alarm-5 <i>Defines the text to be displayed for General Alarm 5</i>	(16 Character String)	ALARM 5	
General Alarm-6 <i>Defines the text to be displayed for General Alarm 6</i>	(16 Character String)	ALARM 6	
General Alarm-7 <i>Defines the text to be displayed for General Alarm 7</i>	(16 Character String)	ALARM 7	
General Alarm-8 <i>Defines the text to be displayed for General Alarm 8</i>	(16 Character String)	ALARM 8	

Description	Range	Default	Setting
General Alarm-9 <i>Defines the text to be displayed for General Alarm 9</i>	(16 Character String)	ALARM 9	
General Alarm-10 <i>Defines the text to be displayed for General Alarm 10</i>	(16 Character String)	ALARM 10	
General Alarm-11 <i>Defines the text to be displayed for General Alarm 11</i>	(16 Character String)	ALARM 11	
General Alarm-12 <i>Defines the text to be displayed for General Alarm 12</i>	(16 Character String)	ALARM 12	

## 2.10.Output Config

### 2.10.1. Output Matrix

Description	Range	Default	Setting
Protection Healthy <i>Relays selected are energised whilst relay self-monitoring does NOT detect any hardware or software errors and DC Supply is healthy. A changeover contact or normally closed contact may be used to generate Protection Defective from this output</i>	Combination of ( BO1, BO2, BO3, BO4, BO5, BO6, BO7, BO8, BO9, BO10, BO11, BO12, BO13, BO14, L1, L2, L3, L4, L5, L6, L7, L8, L9, L10, L11, L12, L13, L14, V1, V2, V3, V4, V5, V6, V7, V8, V9, V10, V11, V12, V13, V14, V15, V16 )	BO1	
51-1 <i>51-1 IDMTL/DTL Overcurrent operated</i>	Combination of ( BO1, BO2, BO3, BO4, BO5, BO6, BO7, BO8, BO9, BO10, BO11, BO12, BO13, BO14, L1, L2, L3, L4, L5, L6, L7, L8, L9, L10, L11, L12, L13, L14, V1, V2, V3, V4, V5, V6, V7, V8, V9, V10, V11, V12, V13, V14, V15, V16 )	----- ----- -----	
51-2 <i>51-2 IDMTL/DTL Overcurrent operated</i>	Combination of ( BO1, BO2, BO3, BO4, BO5, BO6, BO7, BO8, BO9, BO10, BO11, BO12, BO13, BO14, L1, L2, L3, L4, L5, L6, L7, L8, L9, L10, L11, L12, L13, L14, V1, V2, V3, V4, V5, V6, V7, V8, V9, V10, V11, V12, V13, V14, V15, V16 )	----- ----- -----	
51-3 <i>51-3 IDMTL/DTL Overcurrent operated</i>	Combination of ( BO1, BO2, BO3, BO4, BO5, BO6, BO7, BO8, BO9, BO10, BO11, BO12, BO13, BO14, L1, L2, L3, L4, L5, L6, L7, L8, L9, L10, L11, L12, L13, L14, V1, V2, V3, V4, V5, V6, V7, V8, V9, V10, V11, V12, V13, V14, V15, V16 )	----- ----- -----	



Description	Range	Default	Setting
51-4 <i>51-4 IDMTL/DTL Overcurrent operated</i>	Combination of ( BO1, BO2, BO3, BO4, BO5, BO6, BO7, BO8, BO9, BO10, BO11, BO12, BO13, BO14, L1, L2, L3, L4, L5, L6, L7, L8, L9, L10, L11, L12, L13, L14, V1, V2, V3, V4, V5, V6, V7, V8, V9, V10, V11, V12, V13, V14, V15, V16 )	----- ----- -----	
50-1 <i>50-1 INST/DTL Overcurrent operated</i>	Combination of ( BO1, BO2, BO3, BO4, BO5, BO6, BO7, BO8, BO9, BO10, BO11, BO12, BO13, BO14, L1, L2, L3, L4, L5, L6, L7, L8, L9, L10, L11, L12, L13, L14, V1, V2, V3, V4, V5, V6, V7, V8, V9, V10, V11, V12, V13, V14, V15, V16 )	----- ----- -----	
50-2 <i>50-2 INST/DTL Overcurrent operated</i>	Combination of ( BO1, BO2, BO3, BO4, BO5, BO6, BO7, BO8, BO9, BO10, BO11, BO12, BO13, BO14, L1, L2, L3, L4, L5, L6, L7, L8, L9, L10, L11, L12, L13, L14, V1, V2, V3, V4, V5, V6, V7, V8, V9, V10, V11, V12, V13, V14, V15, V16 )	----- ----- -----	
50-3 <i>50-3 INST/DTL Overcurrent operated</i>	Combination of ( BO1, BO2, BO3, BO4, BO5, BO6, BO7, BO8, BO9, BO10, BO11, BO12, BO13, BO14, L1, L2, L3, L4, L5, L6, L7, L8, L9, L10, L11, L12, L13, L14, V1, V2, V3, V4, V5, V6, V7, V8, V9, V10, V11, V12, V13, V14, V15, V16 )	----- ----- -----	
50-4 <i>50-4 INST/DTL Overcurrent operated</i>	Combination of ( BO1, BO2, BO3, BO4, BO5, BO6, BO7, BO8, BO9, BO10, BO11, BO12, BO13, BO14, L1, L2, L3, L4, L5, L6, L7, L8, L9, L10, L11, L12, L13, L14, V1, V2, V3, V4, V5, V6, V7, V8, V9, V10, V11, V12, V13, V14, V15, V16 )	----- ----- -----	
51G-1 <i>51G-1 IDMTL/DTL measured Ground Fault operated</i>	Combination of ( BO1, BO2, BO3, BO4, BO5, BO6, BO7, BO8, BO9, BO10, BO11, BO12, BO13, BO14, L1, L2, L3, L4, L5, L6, L7, L8, L9, L10, L11, L12, L13, L14, V1, V2, V3, V4, V5, V6, V7, V8, V9, V10, V11, V12, V13, V14, V15, V16 )	L4	

<b>Description</b>	<b>Range</b>	<b>Default</b>	<b>Setting</b>
51G-2 <i>51G-2 IDMTL/DTL measured Ground Fault operated</i>	Combination of ( BO1, BO2, BO3, BO4, BO5, BO6, BO7, BO8, BO9, BO10, BO11, BO12, BO13, BO14, L1, L2, L3, L4, L5, L6, L7, L8, L9, L10, L11, L12, L13, L14, V1, V2, V3, V4, V5, V6, V7, V8, V9, V10, V11, V12, V13, V14, V15, V16 )	L4	
51G-3 <i>51G-3 IDMTL/DTL measured Ground Fault operated</i>	Combination of ( BO1, BO2, BO3, BO4, BO5, BO6, BO7, BO8, BO9, BO10, BO11, BO12, BO13, BO14, L1, L2, L3, L4, L5, L6, L7, L8, L9, L10, L11, L12, L13, L14, V1, V2, V3, V4, V5, V6, V7, V8, V9, V10, V11, V12, V13, V14, V15, V16 )	L4	
51G-4 <i>51G-4 IDMTL/DTL measured Ground Fault operated</i>	Combination of ( BO1, BO2, BO3, BO4, BO5, BO6, BO7, BO8, BO9, BO10, BO11, BO12, BO13, BO14, L1, L2, L3, L4, L5, L6, L7, L8, L9, L10, L11, L12, L13, L14, V1, V2, V3, V4, V5, V6, V7, V8, V9, V10, V11, V12, V13, V14, V15, V16 )	L4	
50G-1 <i>50G-1 INST/DTL measured Ground Fault operated</i>	Combination of ( BO1, BO2, BO3, BO4, BO5, BO6, BO7, BO8, BO9, BO10, BO11, BO12, BO13, BO14, L1, L2, L3, L4, L5, L6, L7, L8, L9, L10, L11, L12, L13, L14, V1, V2, V3, V4, V5, V6, V7, V8, V9, V10, V11, V12, V13, V14, V15, V16 )	L4	
50G-2 <i>50G-2 INST/DTL measured Ground Fault operated</i>	Combination of ( BO1, BO2, BO3, BO4, BO5, BO6, BO7, BO8, BO9, BO10, BO11, BO12, BO13, BO14, L1, L2, L3, L4, L5, L6, L7, L8, L9, L10, L11, L12, L13, L14, V1, V2, V3, V4, V5, V6, V7, V8, V9, V10, V11, V12, V13, V14, V15, V16 )	L4	
50G-3 <i>50G-3 INST/DTL measured Ground Fault operated</i>	Combination of ( BO1, BO2, BO3, BO4, BO5, BO6, BO7, BO8, BO9, BO10, BO11, BO12, BO13, BO14, L1, L2, L3, L4, L5, L6, L7, L8, L9, L10, L11, L12, L13, L14, V1, V2, V3, V4, V5, V6, V7, V8, V9, V10, V11, V12, V13, V14, V15, V16 )	L4	

<b>Description</b>	<b>Range</b>	<b>Default</b>	<b>Setting</b>
50G-4 <i>50G-4 INST/DTL measured Ground Fault operated</i>	Combination of ( BO1, BO2, BO3, BO4, BO5, BO6, BO7, BO8, BO9, BO10, BO11, BO12, BO13, BO14, L1, L2, L3, L4, L5, L6, L7, L8, L9, L10, L11, L12, L13, L14, V1, V2, V3, V4, V5, V6, V7, V8, V9, V10, V11, V12, V13, V14, V15, V16 )	L4	
51SGF-1 <i>51SGF-1 IDMTL/DTL sensitive Ground Fault operated</i>	Combination of ( BO1, BO2, BO3, BO4, BO5, BO6, BO7, BO8, BO9, BO10, BO11, BO12, BO13, BO14, L1, L2, L3, L4, L5, L6, L7, L8, L9, L10, L11, L12, L13, L14, V1, V2, V3, V4, V5, V6, V7, V8, V9, V10, V11, V12, V13, V14, V15, V16 )	L5	
51SGF-2 <i>51SGF-2 IDMTL/DTL sensitive Ground Fault operated</i>	Combination of ( BO1, BO2, BO3, BO4, BO5, BO6, BO7, BO8, BO9, BO10, BO11, BO12, BO13, BO14, L1, L2, L3, L4, L5, L6, L7, L8, L9, L10, L11, L12, L13, L14, V1, V2, V3, V4, V5, V6, V7, V8, V9, V10, V11, V12, V13, V14, V15, V16 )	L5	
51SGF-3 <i>51SGF-3 IDMTL/DTL sensitive Ground Fault operated</i>	Combination of ( BO1, BO2, BO3, BO4, BO5, BO6, BO7, BO8, BO9, BO10, BO11, BO12, BO13, BO14, L1, L2, L3, L4, L5, L6, L7, L8, L9, L10, L11, L12, L13, L14, V1, V2, V3, V4, V5, V6, V7, V8, V9, V10, V11, V12, V13, V14, V15, V16 )	L5	
51SGF-4 <i>51SGF-4 IDMTL/DTL sensitive Ground Fault operated</i>	Combination of ( BO1, BO2, BO3, BO4, BO5, BO6, BO7, BO8, BO9, BO10, BO11, BO12, BO13, BO14, L1, L2, L3, L4, L5, L6, L7, L8, L9, L10, L11, L12, L13, L14, V1, V2, V3, V4, V5, V6, V7, V8, V9, V10, V11, V12, V13, V14, V15, V16 )	L5	
50SGF-1 <i>50SGF-1 INST/DTL sensitive Ground Fault operated</i>	Combination of ( BO1, BO2, BO3, BO4, BO5, BO6, BO7, BO8, BO9, BO10, BO11, BO12, BO13, BO14, L1, L2, L3, L4, L5, L6, L7, L8, L9, L10, L11, L12, L13, L14, V1, V2, V3, V4, V5, V6, V7, V8, V9, V10, V11, V12, V13, V14, V15, V16 )	L5	

Description	Range	Default	Setting
50SGF-2 <i>50SGF-2 INST/DTL sensitive Ground Fault operated</i>	Combination of ( BO1, BO2, BO3, BO4, BO5, BO6, BO7, BO8, BO9, BO10, BO11, BO12, BO13, BO14, L1, L2, L3, L4, L5, L6, L7, L8, L9, L10, L11, L12, L13, L14, V1, V2, V3, V4, V5, V6, V7, V8, V9, V10, V11, V12, V13, V14, V15, V16 )	L5	
50SGF-3 <i>50SGF-3 INST/DTL sensitive Ground Fault operated</i>	Combination of ( BO1, BO2, BO3, BO4, BO5, BO6, BO7, BO8, BO9, BO10, BO11, BO12, BO13, BO14, L1, L2, L3, L4, L5, L6, L7, L8, L9, L10, L11, L12, L13, L14, V1, V2, V3, V4, V5, V6, V7, V8, V9, V10, V11, V12, V13, V14, V15, V16 )	L5	
50SGF-4 <i>50SGF-4 INST/DTL sensitive Ground Fault operated</i>	Combination of ( BO1, BO2, BO3, BO4, BO5, BO6, BO7, BO8, BO9, BO10, BO11, BO12, BO13, BO14, L1, L2, L3, L4, L5, L6, L7, L8, L9, L10, L11, L12, L13, L14, V1, V2, V3, V4, V5, V6, V7, V8, V9, V10, V11, V12, V13, V14, V15, V16 )	L5	
64H <i>64H Restricted Ground Fault element operated</i>	Combination of ( BO1, BO2, BO3, BO4, BO5, BO6, BO7, BO8, BO9, BO10, BO11, BO12, BO13, BO14, L1, L2, L3, L4, L5, L6, L7, L8, L9, L10, L11, L12, L13, L14, V1, V2, V3, V4, V5, V6, V7, V8, V9, V10, V11, V12, V13, V14, V15, V16 )	----- ----- -----	
Cold Load Active <i>Cold Load settings are active</i>	Combination of ( BO1, BO2, BO3, BO4, BO5, BO6, BO7, BO8, BO9, BO10, BO11, BO12, BO13, BO14, L1, L2, L3, L4, L5, L6, L7, L8, L9, L10, L11, L12, L13, L14, V1, V2, V3, V4, V5, V6, V7, V8, V9, V10, V11, V12, V13, V14, V15, V16 )	----- ----- -----	
46IT <i>IDMTL/DTL NPS Overcurrent operated</i>	Combination of ( BO1, BO2, BO3, BO4, BO5, BO6, BO7, BO8, BO9, BO10, BO11, BO12, BO13, BO14, L1, L2, L3, L4, L5, L6, L7, L8, L9, L10, L11, L12, L13, L14, V1, V2, V3, V4, V5, V6, V7, V8, V9, V10, V11, V12, V13, V14, V15, V16 )	----- ----- -----	

Description	Range	Default	Setting
46DT <i>INST/DTL NPS Overcurrent operated</i>	Combination of ( BO1, BO2, BO3, BO4, BO5, BO6, BO7, BO8, BO9, BO10, BO11, BO12, BO13, BO14, L1, L2, L3, L4, L5, L6, L7, L8, L9, L10, L11, L12, L13, L14, V1, V2, V3, V4, V5, V6, V7, V8, V9, V10, V11, V12, V13, V14, V15, V16 )	----- ----- -----	
37-1 <i>37-1 Under Current operated</i>	Combination of ( BO1, BO2, BO3, BO4, BO5, BO6, BO7, BO8, BO9, BO10, BO11, BO12, BO13, BO14, L1, L2, L3, L4, L5, L6, L7, L8, L9, L10, L11, L12, L13, L14, V1, V2, V3, V4, V5, V6, V7, V8, V9, V10, V11, V12, V13, V14, V15, V16 )	----- ----- -----	
37-2 <i>37-2 Under Current operated</i>	Combination of ( BO1, BO2, BO3, BO4, BO5, BO6, BO7, BO8, BO9, BO10, BO11, BO12, BO13, BO14, L1, L2, L3, L4, L5, L6, L7, L8, L9, L10, L11, L12, L13, L14, V1, V2, V3, V4, V5, V6, V7, V8, V9, V10, V11, V12, V13, V14, V15, V16 )	----- ----- -----	
49 Trip <i>Thermal capacity trip operated</i>	Combination of ( BO1, BO2, BO3, BO4, BO5, BO6, BO7, BO8, BO9, BO10, BO11, BO12, BO13, BO14, L1, L2, L3, L4, L5, L6, L7, L8, L9, L10, L11, L12, L13, L14, V1, V2, V3, V4, V5, V6, V7, V8, V9, V10, V11, V12, V13, V14, V15, V16 )	----- ----- -----	
49 Alarm <i>Thermal capacity alarm operated</i>	Combination of ( BO1, BO2, BO3, BO4, BO5, BO6, BO7, BO8, BO9, BO10, BO11, BO12, BO13, BO14, L1, L2, L3, L4, L5, L6, L7, L8, L9, L10, L11, L12, L13, L14, V1, V2, V3, V4, V5, V6, V7, V8, V9, V10, V11, V12, V13, V14, V15, V16 )	----- ----- -----	
27/59-1 <i>Under/Overtoltage stage 1 operated</i>	Combination of ( BO1, BO2, BO3, BO4, BO5, BO6, BO7, BO8, BO9, BO10, BO11, BO12, BO13, BO14, L1, L2, L3, L4, L5, L6, L7, L8, L9, L10, L11, L12, L13, L14, V1, V2, V3, V4, V5, V6, V7, V8, V9, V10, V11, V12, V13, V14, V15, V16 )	----- ----- -----	

Description	Range	Default	Setting
27/59-2 <i>Under/Overtension stage 2 operated</i>	Combination of ( BO1, BO2, BO3, BO4, BO5, BO6, BO7, BO8, BO9, BO10, BO11, BO12, BO13, BO14, L1, L2, L3, L4, L5, L6, L7, L8, L9, L10, L11, L12, L13, L14, V1, V2, V3, V4, V5, V6, V7, V8, V9, V10, V11, V12, V13, V14, V15, V16 )	----- ----- -----	
27/59-3 <i>Under/Overtension stage 3 operated</i>	Combination of ( BO1, BO2, BO3, BO4, BO5, BO6, BO7, BO8, BO9, BO10, BO11, BO12, BO13, BO14, L1, L2, L3, L4, L5, L6, L7, L8, L9, L10, L11, L12, L13, L14, V1, V2, V3, V4, V5, V6, V7, V8, V9, V10, V11, V12, V13, V14, V15, V16 )	----- ----- -----	
27/59-4 <i>Under/Overtension stage 4 operated</i>	Combination of ( BO1, BO2, BO3, BO4, BO5, BO6, BO7, BO8, BO9, BO10, BO11, BO12, BO13, BO14, L1, L2, L3, L4, L5, L6, L7, L8, L9, L10, L11, L12, L13, L14, V1, V2, V3, V4, V5, V6, V7, V8, V9, V10, V11, V12, V13, V14, V15, V16 )	----- ----- -----	
Vx 27/59 <i>Under/Overtension Vx stage operated</i>	Combination of ( BO1, BO2, BO3, BO4, BO5, BO6, BO7, BO8, BO9, BO10, BO11, BO12, BO13, BO14, L1, L2, L3, L4, L5, L6, L7, L8, L9, L10, L11, L12, L13, L14, V1, V2, V3, V4, V5, V6, V7, V8, V9, V10, V11, V12, V13, V14, V15, V16 )	----- ----- -----	
47-1 <i>INST/DTL NPS Overtension stage 1 operated</i>	Combination of ( BO1, BO2, BO3, BO4, BO5, BO6, BO7, BO8, BO9, BO10, BO11, BO12, BO13, BO14, L1, L2, L3, L4, L5, L6, L7, L8, L9, L10, L11, L12, L13, L14, V1, V2, V3, V4, V5, V6, V7, V8, V9, V10, V11, V12, V13, V14, V15, V16 )	----- ----- -----	
47-2 <i>INST/DTL NPS Overtension stage 2 operated</i>	Combination of ( BO1, BO2, BO3, BO4, BO5, BO6, BO7, BO8, BO9, BO10, BO11, BO12, BO13, BO14, L1, L2, L3, L4, L5, L6, L7, L8, L9, L10, L11, L12, L13, L14, V1, V2, V3, V4, V5, V6, V7, V8, V9, V10, V11, V12, V13, V14, V15, V16 )	----- ----- -----	

Description	Range	Default	Setting
59NIT <i>Neutral Overvoltage IDMTL/DTL operated</i>	Combination of ( BO1, BO2, BO3, BO4, BO5, BO6, BO7, BO8, BO9, BO10, BO11, BO12, BO13, BO14, L1, L2, L3, L4, L5, L6, L7, L8, L9, L10, L11, L12, L13, L14, V1, V2, V3, V4, V5, V6, V7, V8, V9, V10, V11, V12, V13, V14, V15, V16 )	----- ----- -----	
59NDT <i>Neutral Overvoltage INST/DTL operated</i>	Combination of ( BO1, BO2, BO3, BO4, BO5, BO6, BO7, BO8, BO9, BO10, BO11, BO12, BO13, BO14, L1, L2, L3, L4, L5, L6, L7, L8, L9, L10, L11, L12, L13, L14, V1, V2, V3, V4, V5, V6, V7, V8, V9, V10, V11, V12, V13, V14, V15, V16 )	----- ----- -----	
81-1 <i>Under/Over frequency stage 1 operated</i>	Combination of ( BO1, BO2, BO3, BO4, BO5, BO6, BO7, BO8, BO9, BO10, BO11, BO12, BO13, BO14, L1, L2, L3, L4, L5, L6, L7, L8, L9, L10, L11, L12, L13, L14, V1, V2, V3, V4, V5, V6, V7, V8, V9, V10, V11, V12, V13, V14, V15, V16 )	----- ----- -----	
81-2 <i>Under/Over frequency stage 2 operated</i>	Combination of ( BO1, BO2, BO3, BO4, BO5, BO6, BO7, BO8, BO9, BO10, BO11, BO12, BO13, BO14, L1, L2, L3, L4, L5, L6, L7, L8, L9, L10, L11, L12, L13, L14, V1, V2, V3, V4, V5, V6, V7, V8, V9, V10, V11, V12, V13, V14, V15, V16 )	----- ----- -----	
81-3 <i>Under/Over frequency stage 3 operated</i>	Combination of ( BO1, BO2, BO3, BO4, BO5, BO6, BO7, BO8, BO9, BO10, BO11, BO12, BO13, BO14, L1, L2, L3, L4, L5, L6, L7, L8, L9, L10, L11, L12, L13, L14, V1, V2, V3, V4, V5, V6, V7, V8, V9, V10, V11, V12, V13, V14, V15, V16 )	----- ----- -----	
81-4 <i>Under/Over frequency stage 4 operated</i>	Combination of ( BO1, BO2, BO3, BO4, BO5, BO6, BO7, BO8, BO9, BO10, BO11, BO12, BO13, BO14, L1, L2, L3, L4, L5, L6, L7, L8, L9, L10, L11, L12, L13, L14, V1, V2, V3, V4, V5, V6, V7, V8, V9, V10, V11, V12, V13, V14, V15, V16 )	----- ----- -----	

Description	Range	Default	Setting
60CTS <i>CT Supervision element operated</i>	Combination of ( BO1, BO2, BO3, BO4, BO5, BO6, BO7, BO8, BO9, BO10, BO11, BO12, BO13, BO14, L1, L2, L3, L4, L5, L6, L7, L8, L9, L10, L11, L12, L13, L14, V1, V2, V3, V4, V5, V6, V7, V8, V9, V10, V11, V12, V13, V14, V15, V16 )	----- ----- -----	
46BC <i>46 Broken Conductor element operated</i>	Combination of ( BO1, BO2, BO3, BO4, BO5, BO6, BO7, BO8, BO9, BO10, BO11, BO12, BO13, BO14, L1, L2, L3, L4, L5, L6, L7, L8, L9, L10, L11, L12, L13, L14, V1, V2, V3, V4, V5, V6, V7, V8, V9, V10, V11, V12, V13, V14, V15, V16 )	----- ----- -----	
74TCS-1 <i>Selects which inputs are monitoring trip circuits</i>	Combination of ( BO1, BO2, BO3, BO4, BO5, BO6, BO7, BO8, BO9, BO10, BO11, BO12, BO13, BO14, L1, L2, L3, L4, L5, L6, L7, L8, L9, L10, L11, L12, L13, L14, V1, V2, V3, V4, V5, V6, V7, V8, V9, V10, V11, V12, V13, V14, V15, V16 )	----- ----- -----	
74TCS-2 <i>As Above</i>	Combination of ( BO1, BO2, BO3, BO4, BO5, BO6, BO7, BO8, BO9, BO10, BO11, BO12, BO13, BO14, L1, L2, L3, L4, L5, L6, L7, L8, L9, L10, L11, L12, L13, L14, V1, V2, V3, V4, V5, V6, V7, V8, V9, V10, V11, V12, V13, V14, V15, V16 )	----- ----- -----	
74TCS-3 <i>As Above</i>	Combination of ( BO1, BO2, BO3, BO4, BO5, BO6, BO7, BO8, BO9, BO10, BO11, BO12, BO13, BO14, L1, L2, L3, L4, L5, L6, L7, L8, L9, L10, L11, L12, L13, L14, V1, V2, V3, V4, V5, V6, V7, V8, V9, V10, V11, V12, V13, V14, V15, V16 )	----- ----- -----	
General Pickup <i>General Pickup operated</i>	Combination of ( BO1, BO2, BO3, BO4, BO5, BO6, BO7, BO8, BO9, BO10, BO11, BO12, BO13, BO14, L1, L2, L3, L4, L5, L6, L7, L8, L9, L10, L11, L12, L13, L14, V1, V2, V3, V4, V5, V6, V7, V8, V9, V10, V11, V12, V13, V14, V15, V16 )	----- ----- -----	



Description	Range	Default	Setting
LOV-A Live <i>The A Side is classed as Live</i>	Combination of ( BO1, BO2, BO3, BO4, BO5, BO6, BO7, BO8, BO9, BO10, BO11, BO12, BO13, BO14, L1, L2, L3, L4, L5, L6, L7, L8, L9, L10, L11, L12, L13, L14, L15, L16, L17, L18, L19, L20, V1, V2, V3, V4, V5, V6, V7, V8, V9, V10, V11, V12, V13, V14, V15, V16 )	----- ----- -----	
LOV-X Live <i>The X Side is classed as Live</i>	Combination of ( BO1, BO2, BO3, BO4, BO5, BO6, BO7, BO8, BO9, BO10, BO11, BO12, BO13, BO14, L1, L2, L3, L4, L5, L6, L7, L8, L9, L10, L11, L12, L13, L14, L15, L16, L17, L18, L19, L20, V1, V2, V3, V4, V5, V6, V7, V8, V9, V10, V11, V12, V13, V14, V15, V16 )	----- ----- -----	
LOV In Progress <i>Loss Of Voltage Automation is in progress.</i>	Combination of ( BO1, BO2, BO3, BO4, BO5, BO6, BO7, BO8, BO9, BO10, BO11, BO12, BO13, BO14, L1, L2, L3, L4, L5, L6, L7, L8, L9, L10, L11, L12, L13, L14, L15, L16, L17, L18, L19, L20, V1, V2, V3, V4, V5, V6, V7, V8, V9, V10, V11, V12, V13, V14, V15, V16 )	----- ----- -----	
LOV Fail <i>Loss Of Voltage Automation did not complete successfully.</i>	Combination of ( BO1, BO2, BO3, BO4, BO5, BO6, BO7, BO8, BO9, BO10, BO11, BO12, BO13, BO14, L1, L2, L3, L4, L5, L6, L7, L8, L9, L10, L11, L12, L13, L14, L15, L16, L17, L18, L19, L20, V1, V2, V3, V4, V5, V6, V7, V8, V9, V10, V11, V12, V13, V14, V15, V16 )	----- ----- -----	
50BF-1 <i>Circuit Breaker Fail stage 1 operated</i>	Combination of ( BO1, BO2, BO3, BO4, BO5, BO6, BO7, BO8, BO9, BO10, BO11, BO12, BO13, BO14, L1, L2, L3, L4, L5, L6, L7, L8, L9, L10, L11, L12, L13, L14, V1, V2, V3, V4, V5, V6, V7, V8, V9, V10, V11, V12, V13, V14, V15, V16 )	----- ----- -----	
50BF-2 <i>Circuit Breaker Fail stage 2 operated</i>	Combination of ( BO1, BO2, BO3, BO4, BO5, BO6, BO7, BO8, BO9, BO10, BO11, BO12, BO13, BO14, L1, L2, L3, L4, L5, L6, L7, L8, L9, L10, L11, L12, L13, L14, V1, V2, V3, V4, V5, V6, V7, V8, V9, V10, V11, V12, V13, V14, V15, V16 )	----- ----- -----	

Description	Range	Default	Setting
60VTS <i>VT Supervision element operated</i>	Combination of ( BO1, BO2, BO3, BO4, BO5, BO6, BO7, BO8, BO9, BO10, BO11, BO12, BO13, BO14, L1, L2, L3, L4, L5, L6, L7, L8, L9, L10, L11, L12, L13, L14, V1, V2, V3, V4, V5, V6, V7, V8, V9, V10, V11, V12, V13, V14, V15, V16 )	----- ----- -----	
60VTS-X <i>VT Supervision element for x,y,x phases operated.</i>	Combination of ( BO1, BO2, BO3, BO4, BO5, BO6, BO7, BO8, BO9, BO10, BO11, BO12, BO13, BO14, L1, L2, L3, L4, L5, L6, L7, L8, L9, L10, L11, L12, L13, L14, L15, L16, L17, L18, L19, L20, V1, V2, V3, V4, V5, V6, V7, V8, V9, V10, V11, V12, V13, V14, V15, V16 )	----- ----- -----	
CB Total Trip Count <i>Total CB trip count exceeded</i>	Combination of ( BO1, BO2, BO3, BO4, BO5, BO6, BO7, BO8, BO9, BO10, BO11, BO12, BO13, BO14, L1, L2, L3, L4, L5, L6, L7, L8, L9, L10, L11, L12, L13, L14, V1, V2, V3, V4, V5, V6, V7, V8, V9, V10, V11, V12, V13, V14, V15, V16 )	----- ----- -----	
CB Delta Trip Count <i>Delta CB trip count exceeded</i>	Combination of ( BO1, BO2, BO3, BO4, BO5, BO6, BO7, BO8, BO9, BO10, BO11, BO12, BO13, BO14, L1, L2, L3, L4, L5, L6, L7, L8, L9, L10, L11, L12, L13, L14, V1, V2, V3, V4, V5, V6, V7, V8, V9, V10, V11, V12, V13, V14, V15, V16 )	----- ----- -----	
CB Count To ARBlock <i>Count To AR Block CB trip count exceeded</i>	Combination of ( BO1, BO2, BO3, BO4, BO5, BO6, BO7, BO8, BO9, BO10, BO11, BO12, BO13, BO14, L1, L2, L3, L4, L5, L6, L7, L8, L9, L10, L11, L12, L13, L14, V1, V2, V3, V4, V5, V6, V7, V8, V9, V10, V11, V12, V13, V14, V15, V16 )	----- ----- -----	
CB Freq Ops Count <i>CB Frequent Operations count exceeded</i>	Combination of ( BO1, BO2, BO3, BO4, BO5, BO6, BO7, BO8, BO9, BO10, BO11, BO12, BO13, BO14, L1, L2, L3, L4, L5, L6, L7, L8, L9, L10, L11, L12, L13, L14, V1, V2, V3, V4, V5, V6, V7, V8, V9, V10, V11, V12, V13, V14, V15, V16 )	----- ----- -----	

Description	Range	Default	Setting
CB LO Handle Ops <i>CB Lockout Handle Operations count exceeded</i>	Combination of ( BO1, BO2, BO3, BO4, BO5, BO6, BO7, BO8, BO9, BO10, BO11, BO12, BO13, BO14, L1, L2, L3, L4, L5, L6, L7, L8, L9, L10, L11, L12, L13, L14, V1, V2, V3, V4, V5, V6, V7, V8, V9, V10, V11, V12, V13, V14, V15, V16 )	----- ----- -----	
I <sup>2</sup> t CB Wear <i>I<sup>2</sup>t CB Wear limit exceeded</i>	Combination of ( BO1, BO2, BO3, BO4, BO5, BO6, BO7, BO8, BO9, BO10, BO11, BO12, BO13, BO14, L1, L2, L3, L4, L5, L6, L7, L8, L9, L10, L11, L12, L13, L14, V1, V2, V3, V4, V5, V6, V7, V8, V9, V10, V11, V12, V13, V14, V15, V16 )	----- ----- -----	
Battery Test <i>Battery Test is in progress. This can be used to disable battery charger during a battery test.</i>	Combination of ( BO1, BO2, BO3, BO4, BO5, BO6, BO7, BO8, BO9, BO10, BO11, BO12, BO13, BO14, L1, L2, L3, L4, L5, L6, L7, L8, L9, L10, L11, L12, L13, L14, V1, V2, V3, V4, V5, V6, V7, V8, V9, V10, V11, V12, V13, V14, V15, V16 )	----- ----- -----	
Battery Load Test <i>Battery Load Test is in progress. This can be used to apply the battery test load during a battery test.</i>	Combination of ( BO1, BO2, BO3, BO4, BO5, BO6, BO7, BO8, BO9, BO10, BO11, BO12, BO13, BO14, L1, L2, L3, L4, L5, L6, L7, L8, L9, L10, L11, L12, L13, L14, V1, V2, V3, V4, V5, V6, V7, V8, V9, V10, V11, V12, V13, V14, V15, V16 )	----- ----- -----	
Battery Test Pass <i>Indicates whether the last battery test passed.</i>	Combination of ( BO1, BO2, BO3, BO4, BO5, BO6, BO7, BO8, BO9, BO10, BO11, BO12, BO13, BO14, L1, L2, L3, L4, L5, L6, L7, L8, L9, L10, L11, L12, L13, L14, V1, V2, V3, V4, V5, V6, V7, V8, V9, V10, V11, V12, V13, V14, V15, V16 )	----- ----- -----	
Battery Test Fail <i>Indicates whether the last battery test failed.</i>	Combination of ( BO1, BO2, BO3, BO4, BO5, BO6, BO7, BO8, BO9, BO10, BO11, BO12, BO13, BO14, L1, L2, L3, L4, L5, L6, L7, L8, L9, L10, L11, L12, L13, L14, V1, V2, V3, V4, V5, V6, V7, V8, V9, V10, V11, V12, V13, V14, V15, V16 )	----- ----- -----	

Description	Range	Default	Setting
<p>Recovery Fail</p> <p><i>Indicates whether the battery failed to recover back to its pre-test voltage after last battery test.</i></p>	<p>Combination of ( BO1, BO2, BO3, BO4, BO5, BO6, BO7, BO8, BO9, BO10, BO11, BO12, BO13, BO14, L1, L2, L3, L4, L5, L6, L7, L8, L9, L10, L11, L12, L13, L14, V1, V2, V3, V4, V5, V6, V7, V8, V9, V10, V11, V12, V13, V14, V15, V16 )</p>	<p>----- ----- -----</p>	
<p>Ext. Power Good</p> <p><i>Indicates whether the the external battery supply ok.</i></p>	<p>Combination of ( BO1, BO2, BO3, BO4, BO5, BO6, BO7, BO8, BO9, BO10, BO11, BO12, BO13, BO14, L1, L2, L3, L4, L5, L6, L7, L8, L9, L10, L11, L12, L13, L14, V1, V2, V3, V4, V5, V6, V7, V8, V9, V10, V11, V12, V13, V14, V15, V16 )</p>	<p>----- ----- -----</p>	
<p>Battery Healthy</p> <p><i>Indicates whether the current battery voltage is healthy</i></p>	<p>Combination of ( BO1, BO2, BO3, BO4, BO5, BO6, BO7, BO8, BO9, BO10, BO11, BO12, BO13, BO14, L1, L2, L3, L4, L5, L6, L7, L8, L9, L10, L11, L12, L13, L14, V1, V2, V3, V4, V5, V6, V7, V8, V9, V10, V11, V12, V13, V14, V15, V16 )</p>	<p>----- ----- -----</p>	
<p>Capacitor Ready</p> <p><i>Indicates whether the current capacitor status is ready to trip and close.</i></p>	<p>Combination of ( BO1, BO2, BO3, BO4, BO5, BO6, BO7, BO8, BO9, BO10, BO11, BO12, BO13, BO14, L1, L2, L3, L4, L5, L6, L7, L8, L9, L10, L11, L12, L13, L14, V1, V2, V3, V4, V5, V6, V7, V8, V9, V10, V11, V12, V13, V14, V15, V16 )</p>	<p>----- ----- -----</p>	
<p>CapacitorSupplyFail</p> <p><i>Indicates whether the current capacitor status is Supply Failed.</i></p>	<p>Combination of ( BO1, BO2, BO3, BO4, BO5, BO6, BO7, BO8, BO9, BO10, BO11, BO12, BO13, BO14, L1, L2, L3, L4, L5, L6, L7, L8, L9, L10, L11, L12, L13, L14, V1, V2, V3, V4, V5, V6, V7, V8, V9, V10, V11, V12, V13, V14, V15, V16 )</p>	<p>----- ----- -----</p>	
<p>Capacitor Only Trip</p> <p><i>Indicates whether the current capacitor status is Only Trip</i></p>	<p>Combination of ( BO1, BO2, BO3, BO4, BO5, BO6, BO7, BO8, BO9, BO10, BO11, BO12, BO13, BO14, L1, L2, L3, L4, L5, L6, L7, L8, L9, L10, L11, L12, L13, L14, V1, V2, V3, V4, V5, V6, V7, V8, V9, V10, V11, V12, V13, V14, V15, V16 )</p>	<p>----- ----- -----</p>	

Description	Range	Default	Setting
Capacitor DBI <i>Indicates whether the current capacitor status is DBI condition.</i>	Combination of ( BO1, BO2, BO3, BO4, BO5, BO6, BO7, BO8, BO9, BO10, BO11, BO12, BO13, BO14, L1, L2, L3, L4, L5, L6, L7, L8, L9, L10, L11, L12, L13, L14, V1, V2, V3, V4, V5, V6, V7, V8, V9, V10, V11, V12, V13, V14, V15, V16 )	----- ----- -----	
Cap Test Active <i>Indicates whether the current capacitor status is Supply Failed.</i>	Combination of ( BO1, BO2, BO3, BO4, BO5, BO6, BO7, BO8, BO9, BO10, BO11, BO12, BO13, BO14, L1, L2, L3, L4, L5, L6, L7, L8, L9, L10, L11, L12, L13, L14, V1, V2, V3, V4, V5, V6, V7, V8, V9, V10, V11, V12, V13, V14, V15, V16 )	----- ----- -----	
Cap Test Pass <i>Indicates whether the capacitor test passed.</i>	Combination of ( BO1, BO2, BO3, BO4, BO5, BO6, BO7, BO8, BO9, BO10, BO11, BO12, BO13, BO14, L1, L2, L3, L4, L5, L6, L7, L8, L9, L10, L11, L12, L13, L14, V1, V2, V3, V4, V5, V6, V7, V8, V9, V10, V11, V12, V13, V14, V15, V16 )	----- ----- -----	
Cap Test Fail <i>Indicates whether the capacitor test failed.</i>	Combination of ( BO1, BO2, BO3, BO4, BO5, BO6, BO7, BO8, BO9, BO10, BO11, BO12, BO13, BO14, L1, L2, L3, L4, L5, L6, L7, L8, L9, L10, L11, L12, L13, L14, V1, V2, V3, V4, V5, V6, V7, V8, V9, V10, V11, V12, V13, V14, V15, V16 )	----- ----- -----	
Cap Recovery Fail <i>Indicates whether the capacitor voltage failed to recover after the last capacitor test.</i>	Combination of ( BO1, BO2, BO3, BO4, BO5, BO6, BO7, BO8, BO9, BO10, BO11, BO12, BO13, BO14, L1, L2, L3, L4, L5, L6, L7, L8, L9, L10, L11, L12, L13, L14, V1, V2, V3, V4, V5, V6, V7, V8, V9, V10, V11, V12, V13, V14, V15, V16 )	----- ----- -----	
27Sag Pole1 SARFI <i>Voltage has dropped below the defined SARFI level on Pole 1.</i>	Combination of ( BO1, BO2, BO3, BO4, BO5, BO6, BO7, BO8, BO9, BO10, BO11, BO12, BO13, BO14, L1, L2, L3, L4, L5, L6, L7, L8, L9, L10, L11, L12, L13, L14, V1, V2, V3, V4, V5, V6, V7, V8, V9, V10, V11, V12, V13, V14, V15, V16 )	----- ----- -----	

Description	Range	Default	Setting
27Sag Pole2 SARFI <i>Voltage has dropped below the defined SARFI level on Pole 2.</i>	Combination of ( BO1, BO2, BO3, BO4, BO5, BO6, BO7, BO8, BO9, BO10, BO11, BO12, BO13, BO14, L1, L2, L3, L4, L5, L6, L7, L8, L9, L10, L11, L12, L13, L14, V1, V2, V3, V4, V5, V6, V7, V8, V9, V10, V11, V12, V13, V14, V15, V16 )	----- ----- -----	
27Sag Pole3 SARFI <i>Voltage has dropped below the defined SARFI level on Pole 3.</i>	Combination of ( BO1, BO2, BO3, BO4, BO5, BO6, BO7, BO8, BO9, BO10, BO11, BO12, BO13, BO14, L1, L2, L3, L4, L5, L6, L7, L8, L9, L10, L11, L12, L13, L14, V1, V2, V3, V4, V5, V6, V7, V8, V9, V10, V11, V12, V13, V14, V15, V16 )	----- ----- -----	
59Swell Pole1 SARFI <i>Voltage has risen above the defined SARFI level on Pole 1.</i>	Combination of ( BO1, BO2, BO3, BO4, BO5, BO6, BO7, BO8, BO9, BO10, BO11, BO12, BO13, BO14, L1, L2, L3, L4, L5, L6, L7, L8, L9, L10, L11, L12, L13, L14, V1, V2, V3, V4, V5, V6, V7, V8, V9, V10, V11, V12, V13, V14, V15, V16 )	----- ----- -----	
59Swell Pole2 SARFI <i>Voltage has risen above the defined SARFI level on Pole 2.</i>	Combination of ( BO1, BO2, BO3, BO4, BO5, BO6, BO7, BO8, BO9, BO10, BO11, BO12, BO13, BO14, L1, L2, L3, L4, L5, L6, L7, L8, L9, L10, L11, L12, L13, L14, V1, V2, V3, V4, V5, V6, V7, V8, V9, V10, V11, V12, V13, V14, V15, V16 )	----- ----- -----	
59Swell Pole3 SARFI <i>Voltage has risen above the defined SARFI level on Pole 2.</i>	Combination of ( BO1, BO2, BO3, BO4, BO5, BO6, BO7, BO8, BO9, BO10, BO11, BO12, BO13, BO14, L1, L2, L3, L4, L5, L6, L7, L8, L9, L10, L11, L12, L13, L14, V1, V2, V3, V4, V5, V6, V7, V8, V9, V10, V11, V12, V13, V14, V15, V16 )	----- ----- -----	
Phase A <i>A phase A element operated</i>	Combination of ( BO1, BO2, BO3, BO4, BO5, BO6, BO7, BO8, BO9, BO10, BO11, BO12, BO13, BO14, L1, L2, L3, L4, L5, L6, L7, L8, L9, L10, L11, L12, L13, L14, V1, V2, V3, V4, V5, V6, V7, V8, V9, V10, V11, V12, V13, V14, V15, V16 )	L1	

Description	Range	Default	Setting
Phase B <i>A phase B element operated</i>	Combination of ( BO1, BO2, BO3, BO4, BO5, BO6, BO7, BO8, BO9, BO10, BO11, BO12, BO13, BO14, L1, L2, L3, L4, L5, L6, L7, L8, L9, L10, L11, L12, L13, L14, V1, V2, V3, V4, V5, V6, V7, V8, V9, V10, V11, V12, V13, V14, V15, V16 )	L2	
Phase C <i>A phase C element operated</i>	Combination of ( BO1, BO2, BO3, BO4, BO5, BO6, BO7, BO8, BO9, BO10, BO11, BO12, BO13, BO14, L1, L2, L3, L4, L5, L6, L7, L8, L9, L10, L11, L12, L13, L14, V1, V2, V3, V4, V5, V6, V7, V8, V9, V10, V11, V12, V13, V14, V15, V16 )	L3	
Forward P/F <i>The Phase fault is in the forward direction. Note this output is presented EVEN when relay elements are set to be non-directional.</i>	Combination of ( BO1, BO2, BO3, BO4, BO5, BO6, BO7, BO8, BO9, BO10, BO11, BO12, BO13, BO14, L1, L2, L3, L4, L5, L6, L7, L8, L9, L10, L11, L12, L13, L14, V1, V2, V3, V4, V5, V6, V7, V8, V9, V10, V11, V12, V13, V14, V15, V16 )	----- ----- -----	
Reverse P/F <i>The Phase fault is in the reverse direction. Note this output is presented EVEN when relay elements are set to be non-directional.</i>	Combination of ( BO1, BO2, BO3, BO4, BO5, BO6, BO7, BO8, BO9, BO10, BO11, BO12, BO13, BO14, L1, L2, L3, L4, L5, L6, L7, L8, L9, L10, L11, L12, L13, L14, V1, V2, V3, V4, V5, V6, V7, V8, V9, V10, V11, V12, V13, V14, V15, V16 )	----- ----- -----	
Forward G/F <i>The fault is in the forward direction. Note this output is presented EVEN when relay elements are set to be non-directional.</i>	Combination of ( BO1, BO2, BO3, BO4, BO5, BO6, BO7, BO8, BO9, BO10, BO11, BO12, BO13, BO14, L1, L2, L3, L4, L5, L6, L7, L8, L9, L10, L11, L12, L13, L14, V1, V2, V3, V4, V5, V6, V7, V8, V9, V10, V11, V12, V13, V14, V15, V16 )	----- ----- -----	
Reverse G/F <i>The fault is in the reverse direction. Note this output is presented EVEN when relay elements are set to be non-directional.</i>	Combination of ( BO1, BO2, BO3, BO4, BO5, BO6, BO7, BO8, BO9, BO10, BO11, BO12, BO13, BO14, L1, L2, L3, L4, L5, L6, L7, L8, L9, L10, L11, L12, L13, L14, V1, V2, V3, V4, V5, V6, V7, V8, V9, V10, V11, V12, V13, V14, V15, V16 )	----- ----- -----	

Description	Range	Default	Setting
<p>Forward SGF</p> <p><i>The fault is in the forward direction. Note this output is presented EVEN when relay elements are set to be non-directional.</i></p>	<p>Combination of ( BO1, BO2, BO3, BO4, BO5, BO6, BO7, BO8, BO9, BO10, BO11, BO12, BO13, BO14, L1, L2, L3, L4, L5, L6, L7, L8, L9, L10, L11, L12, L13, L14, V1, V2, V3, V4, V5, V6, V7, V8, V9, V10, V11, V12, V13, V14, V15, V16 )</p>	<p>----- ----- -----</p>	
<p>Reverse SGF</p> <p><i>The fault is in the reverse direction. Note this output is presented EVEN when relay elements are set to be non-directional.</i></p>	<p>Combination of ( BO1, BO2, BO3, BO4, BO5, BO6, BO7, BO8, BO9, BO10, BO11, BO12, BO13, BO14, L1, L2, L3, L4, L5, L6, L7, L8, L9, L10, L11, L12, L13, L14, V1, V2, V3, V4, V5, V6, V7, V8, V9, V10, V11, V12, V13, V14, V15, V16 )</p>	<p>----- ----- -----</p>	
<p>Close CB Blocked</p> <p><i>Indicates that the Close CB control is blocked by its interlocking logic.</i></p>	<p>Combination of ( BO1, BO2, BO3, BO4, BO5, BO6, BO7, BO8, BO9, BO10, BO11, BO12, BO13, BO14, L1, L2, L3, L4, L5, L6, L7, L8, L9, L10, L11, L12, L13, L14, V1, V2, V3, V4, V5, V6, V7, V8, V9, V10, V11, V12, V13, V14, V15, V16 )</p>	<p>----- ----- -----</p>	
<p>Open CB</p> <p><i>Open pulse due to Manual open being issued</i></p>	<p>Combination of ( BO1, BO2, BO3, BO4, BO5, BO6, BO7, BO8, BO9, BO10, BO11, BO12, BO13, BO14, L1, L2, L3, L4, L5, L6, L7, L8, L9, L10, L11, L12, L13, L14, V1, V2, V3, V4, V5, V6, V7, V8, V9, V10, V11, V12, V13, V14, V15, V16 )</p>	<p>----- ----- -----</p>	
<p>CB Closed</p> <p><i>Indicates that the circuit breaker is in the closed position.</i></p>	<p>Combination of ( BO1, BO2, BO3, BO4, BO5, BO6, BO7, BO8, BO9, BO10, BO11, BO12, BO13, BO14, L1, L2, L3, L4, L5, L6, L7, L8, L9, L10, L11, L12, L13, L14, V1, V2, V3, V4, V5, V6, V7, V8, V9, V10, V11, V12, V13, V14, V15, V16 )</p>	<p>----- ----- -----</p>	
<p>CB Open</p> <p><i>Indicates that the circuit breaker is in the open position.</i></p>	<p>Combination of ( BO1, BO2, BO3, BO4, BO5, BO6, BO7, BO8, BO9, BO10, BO11, BO12, BO13, BO14, L1, L2, L3, L4, L5, L6, L7, L8, L9, L10, L11, L12, L13, L14, V1, V2, V3, V4, V5, V6, V7, V8, V9, V10, V11, V12, V13, V14, V15, V16 )</p>	<p>----- ----- -----</p>	



Description	Range	Default	Setting
CB Alarm <i>Indicates the CB is either in an illegal state or is stuck neither open or closed.</i>	Combination of ( BO1, BO2, BO3, BO4, BO5, BO6, BO7, BO8, BO9, BO10, BO11, BO12, BO13, BO14, L1, L2, L3, L4, L5, L6, L7, L8, L9, L10, L11, L12, L13, L14, V1, V2, V3, V4, V5, V6, V7, V8, V9, V10, V11, V12, V13, V14, V15, V16 )	----- ----- -----	
Manual Close CB <i>Close pulse due to Manual close being issued</i>	Combination of ( BO1, BO2, BO3, BO4, BO5, BO6, BO7, BO8, BO9, BO10, BO11, BO12, BO13, BO14, L1, L2, L3, L4, L5, L6, L7, L8, L9, L10, L11, L12, L13, L14, V1, V2, V3, V4, V5, V6, V7, V8, V9, V10, V11, V12, V13, V14, V15, V16 )	----- ----- -----	
79 AR Close CB <i>Close pulse due to auto-reclose sequence</i>	Combination of ( BO1, BO2, BO3, BO4, BO5, BO6, BO7, BO8, BO9, BO10, BO11, BO12, BO13, BO14, L1, L2, L3, L4, L5, L6, L7, L8, L9, L10, L11, L12, L13, L14, V1, V2, V3, V4, V5, V6, V7, V8, V9, V10, V11, V12, V13, V14, V15, V16 )	----- ----- -----	
79 Trip & Reclose <i>Indicates that a trip &amp; reclose has been issued</i>	Combination of ( BO1, BO2, BO3, BO4, BO5, BO6, BO7, BO8, BO9, BO10, BO11, BO12, BO13, BO14, L1, L2, L3, L4, L5, L6, L7, L8, L9, L10, L11, L12, L13, L14, V1, V2, V3, V4, V5, V6, V7, V8, V9, V10, V11, V12, V13, V14, V15, V16 )	----- ----- -----	
79 Trip & Lockout <i>Indicates that a trip &amp; lockout has been issued</i>	Combination of ( BO1, BO2, BO3, BO4, BO5, BO6, BO7, BO8, BO9, BO10, BO11, BO12, BO13, BO14, L1, L2, L3, L4, L5, L6, L7, L8, L9, L10, L11, L12, L13, L14, V1, V2, V3, V4, V5, V6, V7, V8, V9, V10, V11, V12, V13, V14, V15, V16 )	----- ----- -----	
79 Lockout <i>Indicates that the Auto-recloser is in the Lockout state</i>	Combination of ( BO1, BO2, BO3, BO4, BO5, BO6, BO7, BO8, BO9, BO10, BO11, BO12, BO13, BO14, L1, L2, L3, L4, L5, L6, L7, L8, L9, L10, L11, L12, L13, L14, V1, V2, V3, V4, V5, V6, V7, V8, V9, V10, V11, V12, V13, V14, V15, V16 )	----- ----- -----	

Description	Range	Default	Setting
<p>79 Out Of Service <i>Indicates the auto-recloser is out of service</i></p>	<p>Combination of ( BO1, BO2, BO3, BO4, BO5, BO6, BO7, BO8, BO9, BO10, BO11, BO12, BO13, BO14, L1, L2, L3, L4, L5, L6, L7, L8, L9, L10, L11, L12, L13, L14, V1, V2, V3, V4, V5, V6, V7, V8, V9, V10, V11, V12, V13, V14, V15, V16 )</p>	<p>----- ----- -----</p>	
<p>79 In Service <i>Indicates the auto-recloser is in service</i></p>	<p>Combination of ( BO1, BO2, BO3, BO4, BO5, BO6, BO7, BO8, BO9, BO10, BO11, BO12, BO13, BO14, L1, L2, L3, L4, L5, L6, L7, L8, L9, L10, L11, L12, L13, L14, V1, V2, V3, V4, V5, V6, V7, V8, V9, V10, V11, V12, V13, V14, V15, V16 )</p>	<p>----- ----- -----</p>	
<p>79 In Progress <i>Indicates an auto-reclose sequence is in progress</i></p>	<p>Combination of ( BO1, BO2, BO3, BO4, BO5, BO6, BO7, BO8, BO9, BO10, BO11, BO12, BO13, BO14, L1, L2, L3, L4, L5, L6, L7, L8, L9, L10, L11, L12, L13, L14, V1, V2, V3, V4, V5, V6, V7, V8, V9, V10, V11, V12, V13, V14, V15, V16 )</p>	<p>----- ----- -----</p>	
<p>79 Block Extern <i>Indicates that Extern for the current shot has been selected to be delayed. (This may be used to block external tripping elements in the same way as the internal protection elements are blocked to achieve Fast / Delayed operation.)</i></p>	<p>Combination of ( BO1, BO2, BO3, BO4, BO5, BO6, BO7, BO8, BO9, BO10, BO11, BO12, BO13, BO14, L1, L2, L3, L4, L5, L6, L7, L8, L9, L10, L11, L12, L13, L14, V1, V2, V3, V4, V5, V6, V7, V8, V9, V10, V11, V12, V13, V14, V15, V16 )</p>	<p>----- ----- -----</p>	
<p>79 CB Fail To Close <i>Indicates the CB was not closed at the end of the Close Pulse</i></p>	<p>Combination of ( BO1, BO2, BO3, BO4, BO5, BO6, BO7, BO8, BO9, BO10, BO11, BO12, BO13, BO14, L1, L2, L3, L4, L5, L6, L7, L8, L9, L10, L11, L12, L13, L14, V1, V2, V3, V4, V5, V6, V7, V8, V9, V10, V11, V12, V13, V14, V15, V16 )</p>	<p>----- ----- -----</p>	
<p>79 Close Onto Fault <i>Indicates an element starter or trip operated during the Close Pulse</i></p>	<p>Combination of ( BO1, BO2, BO3, BO4, BO5, BO6, BO7, BO8, BO9, BO10, BO11, BO12, BO13, BO14, L1, L2, L3, L4, L5, L6, L7, L8, L9, L10, L11, L12, L13, L14, V1, V2, V3, V4, V5, V6, V7, V8, V9, V10, V11, V12, V13, V14, V15, V16 )</p>	<p>----- ----- -----</p>	

Description	Range	Default	Setting
<p>79 Successful AR</p> <p><i>Indicates that after a reclose and at the end of the Reclaim time the CB was closed and there were no auto-reclose trip elements operated. (This is issued for 2 secs)</i></p>	<p>Combination of ( BO1, BO2, BO3, BO4, BO5, BO6, BO7, BO8, BO9, BO10, BO11, BO12, BO13, BO14, L1, L2, L3, L4, L5, L6, L7, L8, L9, L10, L11, L12, L13, L14, V1, V2, V3, V4, V5, V6, V7, V8, V9, V10, V11, V12, V13, V14, V15, V16 )</p>	<p>----- ----- -----</p>	
<p>Successful Man Close</p> <p><i>Indicates that after a manual close and at the end of the Reclaim time the CB was closed and there were no auto-reclose trip elements operated. (This is issued for 2 secs)</i></p>	<p>Combination of ( BO1, BO2, BO3, BO4, BO5, BO6, BO7, BO8, BO9, BO10, BO11, BO12, BO13, BO14, L1, L2, L3, L4, L5, L6, L7, L8, L9, L10, L11, L12, L13, L14, V1, V2, V3, V4, V5, V6, V7, V8, V9, V10, V11, V12, V13, V14, V15, V16 )</p>	<p>----- ----- -----</p>	
<p>Hot Line Working</p> <p><i>Indicates that Hot LineWorking functionality has been selected</i></p>	<p>Combination of ( BO1, BO2, BO3, BO4, BO5, BO6, BO7, BO8, BO9, BO10, BO11, BO12, BO13, BO14, L1, L2, L3, L4, L5, L6, L7, L8, L9, L10, L11, L12, L13, L14, V1, V2, V3, V4, V5, V6, V7, V8, V9, V10, V11, V12, V13, V14, V15, V16 )</p>	<p>----- ----- -----</p>	
<p>Fast Prot'n Out</p> <p><i>Indicates that the fast protection elements are switched out.</i></p>	<p>Combination of ( BO1, BO2, BO3, BO4, BO5, BO6, BO7, BO8, BO9, BO10, BO11, BO12, BO13, BO14, L1, L2, L3, L4, L5, L6, L7, L8, L9, L10, L11, L12, L13, L14, V1, V2, V3, V4, V5, V6, V7, V8, V9, V10, V11, V12, V13, V14, V15, V16 )</p>	<p>----- ----- -----</p>	
<p>G/F Out</p> <p><i>Indicates that the G/F protection elements are switched out.</i></p>	<p>Combination of ( BO1, BO2, BO3, BO4, BO5, BO6, BO7, BO8, BO9, BO10, BO11, BO12, BO13, BO14, L1, L2, L3, L4, L5, L6, L7, L8, L9, L10, L11, L12, L13, L14, V1, V2, V3, V4, V5, V6, V7, V8, V9, V10, V11, V12, V13, V14, V15, V16 )</p>	<p>----- ----- -----</p>	
<p>SGF Out</p> <p><i>Indicates that the SGF protection elements are switched out.</i></p>	<p>Combination of ( BO1, BO2, BO3, BO4, BO5, BO6, BO7, BO8, BO9, BO10, BO11, BO12, BO13, BO14, L1, L2, L3, L4, L5, L6, L7, L8, L9, L10, L11, L12, L13, L14, V1, V2, V3, V4, V5, V6, V7, V8, V9, V10, V11, V12, V13, V14, V15, V16 )</p>	<p>----- ----- -----</p>	

Description	Range	Default	Setting
<p>LOV Out</p> <p><i>Indicates that the LOV Automation is switched out.</i></p>	<p>Combination of ( BO1, BO2, BO3, BO4, BO5, BO6, BO7, BO8, BO9, BO10, BO11, BO12, BO13, BO14, L1, L2, L3, L4, L5, L6, L7, L8, L9, L10, L11, L12, L13, L14, L15, L16, L17, L18, L19, L20, V1, V2, V3, V4, V5, V6, V7, V8, V9, V10, V11, V12, V13, V14, V15, V16 )</p>	<p>-----</p> <p>-----</p> <p>-----</p>	
<p>New Wave Stored</p> <p><i>The waveform recorder has stored new information Note: this is a pulsed output</i></p>	<p>Combination of ( BO1, BO2, BO3, BO4, BO5, BO6, BO7, BO8, BO9, BO10, BO11, BO12, BO13, BO14, L1, L2, L3, L4, L5, L6, L7, L8, L9, L10, L11, L12, L13, L14, V1, V2, V3, V4, V5, V6, V7, V8, V9, V10, V11, V12, V13, V14, V15, V16 )</p>	<p>-----</p> <p>-----</p> <p>-----</p>	
<p>New Fault Stored</p> <p><i>The fault recorder has stored new information Note: this is a pulsed output</i></p>	<p>Combination of ( BO1, BO2, BO3, BO4, BO5, BO6, BO7, BO8, BO9, BO10, BO11, BO12, BO13, BO14, L1, L2, L3, L4, L5, L6, L7, L8, L9, L10, L11, L12, L13, L14, V1, V2, V3, V4, V5, V6, V7, V8, V9, V10, V11, V12, V13, V14, V15, V16 )</p>	<p>-----</p> <p>-----</p> <p>-----</p>	
<p>Out Of Service Mode</p> <p><i>Indicates that the relay is in Out Of Service Mode</i></p>	<p>Combination of ( BO1, BO2, BO3, BO4, BO5, BO6, BO7, BO8, BO9, BO10, BO11, BO12, BO13, BO14, L1, L2, L3, L4, L5, L6, L7, L8, L9, L10, L11, L12, L13, L14, V1, V2, V3, V4, V5, V6, V7, V8, V9, V10, V11, V12, V13, V14, V15, V16 )</p>	<p>-----</p> <p>-----</p> <p>-----</p>	
<p>Local Mode</p> <p><i>Indicates that the relay is in Local Mode</i></p>	<p>Combination of ( BO1, BO2, BO3, BO4, BO5, BO6, BO7, BO8, BO9, BO10, BO11, BO12, BO13, BO14, L1, L2, L3, L4, L5, L6, L7, L8, L9, L10, L11, L12, L13, L14, V1, V2, V3, V4, V5, V6, V7, V8, V9, V10, V11, V12, V13, V14, V15, V16 )</p>	<p>-----</p> <p>-----</p> <p>-----</p>	
<p>Remote Mode</p> <p><i>Indicates that the relay is in Remote Mode</i></p>	<p>Combination of ( BO1, BO2, BO3, BO4, BO5, BO6, BO7, BO8, BO9, BO10, BO11, BO12, BO13, BO14, L1, L2, L3, L4, L5, L6, L7, L8, L9, L10, L11, L12, L13, L14, V1, V2, V3, V4, V5, V6, V7, V8, V9, V10, V11, V12, V13, V14, V15, V16 )</p>	<p>-----</p> <p>-----</p> <p>-----</p>	

Description	Range	Default	Setting
BI 1 Operated <i>DC Binary Input 1 has operated</i>	Combination of ( BO1, BO2, BO3, BO4, BO5, BO6, BO7, BO8, BO9, BO10, BO11, BO12, BO13, BO14, L1, L2, L3, L4, L5, L6, L7, L8, L9, L10, L11, L12, L13, L14, V1, V2, V3, V4, V5, V6, V7, V8, V9, V10, V11, V12, V13, V14, V15, V16 )	----- ----- -----	
BI 2 Operated <i>DC Binary Input 2 has operated</i>	Combination of ( BO1, BO2, BO3, BO4, BO5, BO6, BO7, BO8, BO9, BO10, BO11, BO12, BO13, BO14, L1, L2, L3, L4, L5, L6, L7, L8, L9, L10, L11, L12, L13, L14, V1, V2, V3, V4, V5, V6, V7, V8, V9, V10, V11, V12, V13, V14, V15, V16 )	----- ----- -----	
BI 3 Operated <i>DC Binary Input 3 has operated</i>	Combination of ( BO1, BO2, BO3, BO4, BO5, BO6, BO7, BO8, BO9, BO10, BO11, BO12, BO13, BO14, L1, L2, L3, L4, L5, L6, L7, L8, L9, L10, L11, L12, L13, L14, V1, V2, V3, V4, V5, V6, V7, V8, V9, V10, V11, V12, V13, V14, V15, V16 )	----- ----- -----	
BI 4 Operated <i>DC Binary Input 4 has operated</i>	Combination of ( BO1, BO2, BO3, BO4, BO5, BO6, BO7, BO8, BO9, BO10, BO11, BO12, BO13, BO14, L1, L2, L3, L4, L5, L6, L7, L8, L9, L10, L11, L12, L13, L14, V1, V2, V3, V4, V5, V6, V7, V8, V9, V10, V11, V12, V13, V14, V15, V16 )	----- ----- -----	
BI 5 Operated <i>DC Binary Input 5 has operated</i>	Combination of ( BO1, BO2, BO3, BO4, BO5, BO6, BO7, BO8, BO9, BO10, BO11, BO12, BO13, BO14, L1, L2, L3, L4, L5, L6, L7, L8, L9, L10, L11, L12, L13, L14, V1, V2, V3, V4, V5, V6, V7, V8, V9, V10, V11, V12, V13, V14, V15, V16 )	----- ----- -----	
BI 6 Operated <i>DC Binary Input 6 has operated</i>	Combination of ( BO1, BO2, BO3, BO4, BO5, BO6, BO7, BO8, BO9, BO10, BO11, BO12, BO13, BO14, L1, L2, L3, L4, L5, L6, L7, L8, L9, L10, L11, L12, L13, L14, V1, V2, V3, V4, V5, V6, V7, V8, V9, V10, V11, V12, V13, V14, V15, V16 )	----- ----- -----	

Description	Range	Default	Setting
BI 7 Operated <i>DC Binary Input 7 has operated</i>	Combination of ( BO1, BO2, BO3, BO4, BO5, BO6, BO7, BO8, BO9, BO10, BO11, BO12, BO13, BO14, L1, L2, L3, L4, L5, L6, L7, L8, L9, L10, L11, L12, L13, L14, V1, V2, V3, V4, V5, V6, V7, V8, V9, V10, V11, V12, V13, V14, V15, V16 )	----- ----- -----	
BI 8 Operated <i>DC Binary Input 8 has operated</i>	Combination of ( BO1, BO2, BO3, BO4, BO5, BO6, BO7, BO8, BO9, BO10, BO11, BO12, BO13, BO14, L1, L2, L3, L4, L5, L6, L7, L8, L9, L10, L11, L12, L13, L14, V1, V2, V3, V4, V5, V6, V7, V8, V9, V10, V11, V12, V13, V14, V15, V16 )	----- ----- -----	
BI 9 Operated <i>DC Binary Input 9 has operated</i>	Combination of ( BO1, BO2, BO3, BO4, BO5, BO6, BO7, BO8, BO9, BO10, BO11, BO12, BO13, BO14, L1, L2, L3, L4, L5, L6, L7, L8, L9, L10, L11, L12, L13, L14, V1, V2, V3, V4, V5, V6, V7, V8, V9, V10, V11, V12, V13, V14, V15, V16 )	----- ----- -----	
BI 10 Operated <i>DC Binary Input 10 has operated</i>	Combination of ( BO1, BO2, BO3, BO4, BO5, BO6, BO7, BO8, BO9, BO10, BO11, BO12, BO13, BO14, L1, L2, L3, L4, L5, L6, L7, L8, L9, L10, L11, L12, L13, L14, V1, V2, V3, V4, V5, V6, V7, V8, V9, V10, V11, V12, V13, V14, V15, V16 )	----- ----- -----	
BI 11 Operated <i>DC Binary Input 11 has operated</i>	Combination of ( BO1, BO2, BO3, BO4, BO5, BO6, BO7, BO8, BO9, BO10, BO11, BO12, BO13, BO14, L1, L2, L3, L4, L5, L6, L7, L8, L9, L10, L11, L12, L13, L14, V1, V2, V3, V4, V5, V6, V7, V8, V9, V10, V11, V12, V13, V14, V15, V16 )	----- ----- -----	
BI 12 Operated <i>DC Binary Input 12 has operated</i>	Combination of ( BO1, BO2, BO3, BO4, BO5, BO6, BO7, BO8, BO9, BO10, BO11, BO12, BO13, BO14, L1, L2, L3, L4, L5, L6, L7, L8, L9, L10, L11, L12, L13, L14, V1, V2, V3, V4, V5, V6, V7, V8, V9, V10, V11, V12, V13, V14, V15, V16 )	----- ----- -----	

Description	Range	Default	Setting
BI 13 Operated <i>DC Binary Input 13 has operated</i>	Combination of ( BO1, BO2, BO3, BO4, BO5, BO6, BO7, BO8, BO9, BO10, BO11, BO12, BO13, BO14, L1, L2, L3, L4, L5, L6, L7, L8, L9, L10, L11, L12, L13, L14, V1, V2, V3, V4, V5, V6, V7, V8, V9, V10, V11, V12, V13, V14, V15, V16 )	----- ----- -----	
E1 <i>Quick Logic equation 1 operated</i>	Combination of ( BO1, BO2, BO3, BO4, BO5, BO6, BO7, BO8, BO9, BO10, BO11, BO12, BO13, BO14, L1, L2, L3, L4, L5, L6, L7, L8, L9, L10, L11, L12, L13, L14, V1, V2, V3, V4, V5, V6, V7, V8, V9, V10, V11, V12, V13, V14, V15, V16 )	----- ----- -----	
E2 <i>Quick Logic equation 2 operated</i>	Combination of ( BO1, BO2, BO3, BO4, BO5, BO6, BO7, BO8, BO9, BO10, BO11, BO12, BO13, BO14, L1, L2, L3, L4, L5, L6, L7, L8, L9, L10, L11, L12, L13, L14, V1, V2, V3, V4, V5, V6, V7, V8, V9, V10, V11, V12, V13, V14, V15, V16 )	----- ----- -----	
E3 <i>Quick Logic equation 3 operated</i>	Combination of ( BO1, BO2, BO3, BO4, BO5, BO6, BO7, BO8, BO9, BO10, BO11, BO12, BO13, BO14, L1, L2, L3, L4, L5, L6, L7, L8, L9, L10, L11, L12, L13, L14, V1, V2, V3, V4, V5, V6, V7, V8, V9, V10, V11, V12, V13, V14, V15, V16 )	----- ----- -----	
E4 <i>Quick Logic equation 4 operated</i>	Combination of ( BO1, BO2, BO3, BO4, BO5, BO6, BO7, BO8, BO9, BO10, BO11, BO12, BO13, BO14, L1, L2, L3, L4, L5, L6, L7, L8, L9, L10, L11, L12, L13, L14, V1, V2, V3, V4, V5, V6, V7, V8, V9, V10, V11, V12, V13, V14, V15, V16 )	----- ----- -----	
E5 <i>Quick Logic equation 5 operated</i>	Combination of ( BO1, BO2, BO3, BO4, BO5, BO6, BO7, BO8, BO9, BO10, BO11, BO12, BO13, BO14, L1, L2, L3, L4, L5, L6, L7, L8, L9, L10, L11, L12, L13, L14, V1, V2, V3, V4, V5, V6, V7, V8, V9, V10, V11, V12, V13, V14, V15, V16 )	----- ----- -----	

Description	Range	Default	Setting
E6 <i>Quick Logic equation 6 operated</i>	Combination of ( BO1, BO2, BO3, BO4, BO5, BO6, BO7, BO8, BO9, BO10, BO11, BO12, BO13, BO14, L1, L2, L3, L4, L5, L6, L7, L8, L9, L10, L11, L12, L13, L14, V1, V2, V3, V4, V5, V6, V7, V8, V9, V10, V11, V12, V13, V14, V15, V16 )	----- ----- -----	
E7 <i>Quick Logic equation 7 operated</i>	Combination of ( BO1, BO2, BO3, BO4, BO5, BO6, BO7, BO8, BO9, BO10, BO11, BO12, BO13, BO14, L1, L2, L3, L4, L5, L6, L7, L8, L9, L10, L11, L12, L13, L14, V1, V2, V3, V4, V5, V6, V7, V8, V9, V10, V11, V12, V13, V14, V15, V16 )	----- ----- -----	
E8 <i>Quick Logic equation 8 operated</i>	Combination of ( BO1, BO2, BO3, BO4, BO5, BO6, BO7, BO8, BO9, BO10, BO11, BO12, BO13, BO14, L1, L2, L3, L4, L5, L6, L7, L8, L9, L10, L11, L12, L13, L14, V1, V2, V3, V4, V5, V6, V7, V8, V9, V10, V11, V12, V13, V14, V15, V16 )	----- ----- -----	
E9 <i>Quick Logic equation 9 operated</i>	Combination of ( BO1, BO2, BO3, BO4, BO5, BO6, BO7, BO8, BO9, BO10, BO11, BO12, BO13, BO14, L1, L2, L3, L4, L5, L6, L7, L8, L9, L10, L11, L12, L13, L14, V1, V2, V3, V4, V5, V6, V7, V8, V9, V10, V11, V12, V13, V14, V15, V16 )	----- ----- -----	
E10 <i>Quick Logic equation 10 operated</i>	Combination of ( BO1, BO2, BO3, BO4, BO5, BO6, BO7, BO8, BO9, BO10, BO11, BO12, BO13, BO14, L1, L2, L3, L4, L5, L6, L7, L8, L9, L10, L11, L12, L13, L14, V1, V2, V3, V4, V5, V6, V7, V8, V9, V10, V11, V12, V13, V14, V15, V16 )	----- ----- -----	
E11 <i>Quick Logic equation 11 operated</i>	Combination of ( BO1, BO2, BO3, BO4, BO5, BO6, BO7, BO8, BO9, BO10, BO11, BO12, BO13, BO14, L1, L2, L3, L4, L5, L6, L7, L8, L9, L10, L11, L12, L13, L14, V1, V2, V3, V4, V5, V6, V7, V8, V9, V10, V11, V12, V13, V14, V15, V16 )	----- ----- -----	



Description	Range	Default	Setting
E12 <i>Quick Logic equation 12 operated</i>	Combination of ( BO1, BO2, BO3, BO4, BO5, BO6, BO7, BO8, BO9, BO10, BO11, BO12, BO13, BO14, L1, L2, L3, L4, L5, L6, L7, L8, L9, L10, L11, L12, L13, L14, V1, V2, V3, V4, V5, V6, V7, V8, V9, V10, V11, V12, V13, V14, V15, V16 )	----- ----- -----	
E13 <i>Quick Logic equation 13 operated</i>	Combination of ( BO1, BO2, BO3, BO4, BO5, BO6, BO7, BO8, BO9, BO10, BO11, BO12, BO13, BO14, L1, L2, L3, L4, L5, L6, L7, L8, L9, L10, L11, L12, L13, L14, V1, V2, V3, V4, V5, V6, V7, V8, V9, V10, V11, V12, V13, V14, V15, V16 )	----- ----- -----	
E14 <i>Quick Logic equation 14 operated</i>	Combination of ( BO1, BO2, BO3, BO4, BO5, BO6, BO7, BO8, BO9, BO10, BO11, BO12, BO13, BO14, L1, L2, L3, L4, L5, L6, L7, L8, L9, L10, L11, L12, L13, L14, V1, V2, V3, V4, V5, V6, V7, V8, V9, V10, V11, V12, V13, V14, V15, V16 )	----- ----- -----	
E15 <i>Quick Logic equation 15 operated</i>	Combination of ( BO1, BO2, BO3, BO4, BO5, BO6, BO7, BO8, BO9, BO10, BO11, BO12, BO13, BO14, L1, L2, L3, L4, L5, L6, L7, L8, L9, L10, L11, L12, L13, L14, V1, V2, V3, V4, V5, V6, V7, V8, V9, V10, V11, V12, V13, V14, V15, V16 )	----- ----- -----	
E16 <i>Quick Logic equation 16 operated</i>	Combination of ( BO1, BO2, BO3, BO4, BO5, BO6, BO7, BO8, BO9, BO10, BO11, BO12, BO13, BO14, L1, L2, L3, L4, L5, L6, L7, L8, L9, L10, L11, L12, L13, L14, V1, V2, V3, V4, V5, V6, V7, V8, V9, V10, V11, V12, V13, V14, V15, V16 )	----- ----- -----	

## 2.10.2. Binary Output Config

Description	Range	Default	Setting
Trip Contacts <i>The Binary Outputs selected by this setting are classed as Trip contacts. (When any of these BOs operate the Trip LED is lit, CB Fail is started, if enabled, &amp; a Fault Record is stored)</i>	Combination of ( BO1, BO2, BO3, BO4, BO5, BO6, BO7, BO8, BO9, BO10, BO11, BO12, BO13, BO14 )	-----	
Hand Reset Outputs <i>Relays selected, as Hand Reset will remain latched until manually reset from front panel or via communications link or by removing DC Supply. By default relays are Self Resetting and will reset when the driving signal is removed.</i>	Combination of ( BO1, BO2, BO3, BO4, BO5, BO6, BO7, BO8, BO9, BO10, BO11, BO12, BO13, BO14, L1, L2, L3, L4, L5, L6, L7, L8, L9, L10, L11, L12, L13, L14 )	L1, L2, L3, L4, L5, L6, L7, L8, L9, L10, L11, L12, L13, L14	
Min Operate Time 1 <i>Minimum operate time of output relay 1</i>	0, 0.01 ... 59, 60	0.1s	
Min Operate Time 2 <i>Minimum operate time of output relay 2</i>	0, 0.01 ... 59, 60	0.1s	
Min Operate Time 3 <i>Minimum operate time of output relay 3</i>	0, 0.01 ... 59, 60	0.1s	
Min Operate Time 4 <i>Minimum operate time of output relay 4</i>	0, 0.01 ... 59, 60	0.1s	
Min Operate Time 5 <i>Minimum operate time of output relay 5</i>	0, 0.01 ... 59, 60	0.1s	
Min Operate Time 6 <i>Minimum operate time of output relay 6</i>	0, 0.01 ... 59, 60	0.1s	
Min Operate Time 7 <i>Minimum operate time of output relay 7</i>	0, 0.01 ... 59, 60	0.1s	
Min Operate Time 8 <i>Minimum operate time of output relay 8</i>	0, 0.01 ... 59, 60	0.1s	
Min Operate Time 9 <i>Minimum operate time of output relay 9</i>	0, 0.01 ... 59, 60	0.1s	
Min Operate Time 10 <i>Minimum operate time of output relay 10</i>	0, 0.01 ... 59, 60	0.1s	
Min Operate Time 11 <i>Minimum operate time of output relay 11</i>	0, 0.01 ... 59, 60	0.1s	
Min Operate Time 12 <i>Minimum operate time of output relay 12</i>	0, 0.01 ... 59, 60	0.1s	
Min Operate Time 13 <i>Minimum operate time of output relay 13</i>	0, 0.01 ... 59, 60	0.1s	
Min Operate Time 14 <i>Minimum operate time of output relay 14</i>	0, 0.01 ... 59, 60	0.1s	

## 2.10.3. LED Config

Description	Range	Default	Setting
Green LEDs <i>Selects which LEDs will be green when driven</i>	Combination of ( 1, 2, 3, 4, 5, 6, 7, 8, 9, 10, 11, 12, 13, 14 )	-----	

Description	Range	Default	Setting
Red LEDs <i>Selects which LEDs will be red when driven</i>	Combination of ( 1, 2, 3, 4, 5, 6, 7, 8, 9, 10, 11, 12, 13, 14 )	1, 2, 3, 4, 5, 6, 7, 8, 9, 10, 11, 12, 13, 14	

## 2.10.4. Pickup Config

Description	Range	Default	Setting
Gn P/F Pickups <i>When any of the selected pickups operate General Pickup is driven.</i>	Combination of ( 51-1, 51-2, 51-3, 51-4, 50-1, 50-2, 50-3, 50-4 )	51-1, 51-2, 51-3, 51-4, 50-1, 50-2, 50-3, 50-4	
Gn G/F Pickups <i>As Above</i>	Combination of ( 51G-1, 51G-2, 51G-3, 51G-4, 50G-1, 50G-2, 50G-3, 50G-4 )	51G-1, 51G-2, 51G-3, 51G-4, 50G-1, 50G-2, 50G-3, 50G-4	
Gn SGF/RGF Pickups <i>As Above</i>	Combination of ( 51SGF-1, 51SGF-2, 51SGF-3, 51SGF-4, 50SGF-1, 50SGF-2, 50SGF-3, 50SGF-4, 64H )	51SGF-1, 51SGF-2, 51SGF-3, 51SGF-4, 50SGF-1, 50SGF-2, 50SGF-3, 50SGF-4, 64H	
Gn Voltage Pickups <i>As Above</i>	Combination of ( 27/59-1, 27/59-2, 27/59-3, 27/59-4, Vx 27/59, 47-1, 47-2, 59NIT, 59NDT )	27/59-1, 27/59-2, 27/59-3, 27/59-4, Vx 27/59, 47-1, 47-2, 59NIT, 59NDT	
Gn Freq Pickups <i>As Above</i>	Combination of ( 81-1, 81-2, 81-3, 81-4 )	81-1, 81-2, 81-3, 81-4	
Gn Misc Pickups <i>As Above</i>	Combination of ( 46IT, 46DT, 37-1, 37-2 )	46IT, 46DT, 37-1, 37-2	

## 2.11.CB Maintenance

## 2.11.1. CB Counters

Description	Range	Default	Setting
Gn CB Total Trip Count <i>Selects whether the CB Total Trip Count counter is enabled</i>	Disabled, Enabled	Disabled	
Gn CB Total Trip Count Target <i>Selects the number of CB trips allowed before CB Total Trip Count counter output operates</i>	0, 1 ... 9999, 10000	100	
Gn CB Total Trip Count Reset <i>Resets CB Total Trip Count counter</i>	No, Yes	No	

Description	Range	Default	Setting
Gn CB Delta Trip Count <i>Selects whether the CB Delta Trip Count counter is enabled</i>	Disabled, Enabled	Disabled	
Gn CB Delta Trip Count Target <i>Selects the number of CB trips allowed before CB Delta Trip Count counter output operates</i>	0, 1 ... 9999, 10000	100	
Gn CB Delta Trip Count Reset <i>Resets CB Delta Trip Count counter</i>	No, Yes	No	
Gn CB Count To AR Block <i>Selects whether the CB Count To AR Block counter is enabled</i>	Disabled, Enabled	Disabled	
Gn CB Count To AR Block Target <i>Selects the number of CB trips allowed before CB Count To AR Block counter output operates. While count is above target the Autorecloser will only perform 1 x Delayed Shot and Lockout</i>	0, 1 ... 9999, 10000	100	
Gn CB Count To AR Block Reset <i>Resets CB Count To AR Block counter</i>	No, Yes	No	
Gn CB Freq Ops Count <i>Selects whether the CB Frequent Operations Counter is enabled</i>	Disabled, Enabled	Disabled	
Gn CB Freq Ops Count Target <i>Selects the number of CB trips allowed before CB Frequent Operations Counter output operates. While count is above target the Autorecloser will only perform 1 x Delayed Shot and Lockout</i>	0, 1 ... 9999, 10000	10	
Gn CB Freq Ops Count Reset <i>Resets CB Frequent Operations Counter</i>	No, Yes	No	
Gn CB LO Handle Ops <i>Selects whether the CB Lockout operations Counter is enabled</i>	Disabled, Enabled	Disabled	
Gn CB LO Handle Ops Target <i>Selects the number of CB Lockout handle operations allowed before CB LO Handle Ops Count counter output operates</i>	0, 1 ... 9999, 10000	100	
Gn CB LO Handle Ops Reset <i>Resets CB Lockout Handle Operations Counter.</i>	No, Yes	No	

2.11.2. I<sup>2</sup>T CB Wear

Description	Range	Default	Setting
Gn I <sup>2</sup> t Counter <i>Selects whether the I<sup>2</sup>t CB Wear monitor is enabled</i>	Disabled, Enabled	Disabled	
Gn Alarm Limit <i>Sets limit before alarm is issued</i>	10, 11 ... 99000, 100000	10MA <sup>2</sup> s	
Gn Separation Time <i>Sets the time for CB mechanism to start moving, time before contacts start to separate</i>	0, 0.001 ... 0.199, 0.2	0.02s	

Description	Range	Default	Setting
Gn Clearance Time <i>Time for CB to clear fault</i>	0, 0.001 ... 0.199, 0.2	0.04s	
Reset I <sup>2</sup> t Count <i>Reset the CB wear count</i>	No, Yes	No	

## 2.12.Data Storage

Description	Range	Default	Setting
Gn P/F Trig Storage <i>Select which elements trigger a waveform record</i>	Combination of ( 51-1, 51-2, 51-3, 51-4, 50-1, 50-2, 50-3, 50-4 )	51-1, 51-2, 51-3, 51-4, 50-1, 50-2, 50-3, 50-4	
Gn G/F Trig Storage <i>As Above</i>	Combination of ( 51G-1, 51G-2, 51G-3, 51G-4, 50G-1, 50G-2, 50G-3, 50G-4 )	51G-1, 51G-2, 51G-3, 51G-4, 50G-1, 50G-2, 50G-3, 50G-4	
Gn SGF/RGF Trig Storage <i>As Above</i>	Combination of ( 51SGF-1, 51SGF-2, 51SGF-3, 51SGF-4, 50SGF-1, 50SGF-2, 50SGF-3, 50SGF-4, 64H )	51SGF-1, 51SGF-2, 51SGF-3, 51SGF-4, 50SGF-1, 50SGF-2, 50SGF-3, 50SGF-4, 64H	
Gn Misc Current Storage <i>As Above</i>	Combination of ( 46IT, 46DT, 37-1, 37-2, 49 Trip, 49 Alarm )	-----	
Gn Voltage Trig Storage <i>As Above</i>	Combination of ( 27/59-1, 27/59-2, 27/59-3, 27/59-4, Vx 27/59, 47-1, 47-2, 59NIT, 59NDT )	-----	
Gn Freq Trig Storage <i>As Above</i>	Combination of ( 81-1, 81-2, 81-3, 81-4 )	----	
Pre-trigger Storage <i>Select Percentage of waveform record stored before the fault is triggered</i>	10, 20, 30, 40, 50, 60, 70, 80, 90	20%	
Record Duration <i>Select waveform record duration</i>	10 Rec x 1 Sec, 5 Rec x 2 Sec, 2 Rec x 5 Sec, 1 Rec x 10 Sec	10 Rec x 1 Sec	
Trigger Waveform <i>Trigger waveform storage</i>	No, Yes	No	
Clear Waveforms <i>Clear all stored waveform records</i>	No, Yes	No	
Gn Max Fault Rec Time <i>Maximum time Fault record information will be stored and classed as same fault</i>	0, 1 ... 59900, 60000	2000ms	
Clear Faults <i>Clear all stored fault records</i>	No, Yes	No	
Clear Events	No, Yes	No	

Description	Range	Default	Setting
<i>Clear all stored event records</i>			
Data Log <i>Selects whether the Data Logger is enabled</i>	Disabled, Enabled	Disabled	
Data Log Period <i>Selects period between stored samples</i>	1, 2, 3, 4, 5, 6, 7, 8, 9, 10, 15, 20, 25, 30, 35, 40, 45, 50, 55, 60	1min	
Clear Data Log <i>Clear the Data Log</i>	No, Yes	No	
Clear Energy <i>Clear all energy values</i>	No, Yes	No	

## 2.13. Communications

Description	Range	Default	Setting
Station Address <i>IEC 60870-5-103 Station Address</i>	0 ... 254	0	
DNP3 Unsolicited Events <i>Allows unsolicited event support in the relay. When Enabled, unsolicited event transmission can be controlled by the Master. When Disabled, Master requests are ignored.</i>	Disabled, Enabled	Disabled	
DNP3 Destination Address <i>The address of the master to which unsolicited events will be sent.</i>	0 ... 65534	0	
COM1-RS485 Protocol <i>Selects protocol to use for COM1-RS485</i>	OFF, IEC60870-5-103, MODBUS-RTU, DNP3	IEC60870-5-103	
COM1-RS485 Baud Rate <i>Sets the communications baud rate for COM1-RS485</i>	75 110 150 300 600 1200 2400 4800 9600 19200 38400	19200	
COM1-RS485 Parity <i>Selects whether parity information is used</i>	NONE, ODD, EVEN	EVEN	
COM2-USB Protocol <i>Selects protocol to use for COM2-USB</i>	OFF, IEC60870-5-103, MODBUS-RTU, ASCII, DNP3	IEC60870-5-103	
COM3 Protocol <i>Selects protocol to use for COM3</i>	OFF, IEC60870-5-103, MODBUS-RTU, DNP3	IEC6-0870-5-103	
COM3 Baud Rate <i>Sets the communications baud rate for COM3</i>	75 110 150 300 600 1200 2400 4800 9600 19200 38400 57600 115200	57600	
COM3 Parity <i>Selects whether parity information is used</i>	NONE, ODD, EVEN	EVEN	
COM3 Line Idle <i>Selects the communications line idle sense</i>	LIGHT ON, LIGHT OFF	LIGHT OFF	
COM3 Data Echo <i>Enables echoing of data from RX port to TX port when operating relays in a Fibre Optic ring configuration</i>	ON, OFF	OFF	
COM4 Protocol <i>Selects protocol to use for COM4</i>	OFF, IEC60870-5-103, MODBUS-RTU, DNP3	OFF	
COM4 Baud Rate	75 110 150 300 600 1200	19200	

Description	Range	Default	Setting
Sets the communications baud rate for COM4	2400 4800 9600 19200 38400		
COM4 Parity <i>Selects whether parity information is used</i>	NONE, OFF, EVEN	EVEN	
COM4 Line Idle <i>Selects the communications line idle sense</i>	LIGHT ON, LIGHT OFF	LIGHT OFF	
COM4 Data Echo <i>Enables echoing of data from RX port to TX port when operating relays in a Fibre Optic ring configuration</i>	ON, OFF	OFF	

### 3. Relay Instrumentation

Instrument	Description
<b>FAVORITE METERS</b>  →to view	<p>This allows the user to view his previously constructed list of 'favorite meters' by pressing TEST/RESET ► button and the READ DOWN button to scroll though the meters added to this sub-group</p> <p>To construct a sub-group of favorite meters, first go to the desired meter then press ENTER this will cause a message to appear on the LCD 'Add To Favorites YES pressing ENTER again will add this to the FAVORITE METERS Sub-menu. To remove a meter from the FAVORITE METERS sub-menu go to that meter each in the FAVORITE METERS sub-menu or at its Primary location press ENTER and the message 'Remove From Favorites' will appear press ENTER again and this meter will be removed from the FAVORITE METERS sub-group</p>
<b>CURRENT METERS</b>  →to view	<p>This is the sub-group that includes all the meters that are associated with Current TEST/RESET ► allows access to this sub-group</p>
Primary Current Ia                    0.00kA Ib                    0.00kA Ic                    0.00kA	Displays the 3 phase currents Primary RMS values
Secondary Current Ia                    0.00A Ib                    0.00A Ic                    0.00A	Displays the 3 phase currents Secondary RMS values
Nom Current Ia                    0.00xIn ---- Ib                    0.00xIn ---- Ic                    0.00xIn ----	Displays the 3 Phase currents Nominal RMS values & phase angles with respect to PPS voltage.
Pri Ground Current In                    0.000kA I <sub>g</sub> 0.000kA I <sub>sgf</sub> 0.000kA	Displays the 3 Ground currents Primary RMS values
Sec Ground Current In                    0.000kA I <sub>g</sub> 0.000kA	Displays the 3 Ground currents Secondary RMS values

Isgf	0.000kA	
Nom Ground Current In Ig Isgf <sub>o</sub>	0.000xIn----° 0.000xIn----° 0.000xIn----	Displays the 3 Ground currents Nominal RMS values & phase angles with respect to PPS voltage.
I Seq Components Izps Ipps <sub>o</sub> Inps <sub>o</sub>	0.00xIn----° 0.00xIn---- 0.00xIn----	Displays the Current Sequence components Nominal RMS values & phase angles with respect to PPS voltage.
2 <sup>nd</sup> Harmonic Current Ia Ib Ic	0.00xIn 0.00xIn 0.00xIn	Displays the 3 phase currents' 2 <sup>nd</sup> Harmonic components Nominal RMS values.

<b>VOLTAGE METERS</b>  →to view		This is the sub-group that includes all the meters that are associated with Voltage TEST/RESET ► allows access to this sub-group
Prim Ph-Ph Voltage Vab Vbc Vca	0.00kV 0.00kV 0.00kV	Displays the Phase to Phase Voltage Primary RMS values
Sec Ph-Ph Voltage Vab <sub>o</sub> Vbc <sub>o</sub> Vca <sub>o</sub>	0.00V ---- 0.00V ---- 0.00V ----	Displays the Phase to Phase Voltage Secondary RMS values & Angles with respect to PPS voltage.
Nominal Ph-Ph Voltage Vab Vbc Vca	0.00V 0.00V 0.00V	Displays the Phase to Phase Voltage Nominal RMS values
Prim Ph-N Voltage Va Vb Vc	0.00kV 0.00kV 0.00kV	Displays the Phase to Neutral Voltage Primary RMS values
Sec Ph-N Voltage Va <sub>o</sub> Vb <sub>o</sub> Vc <sub>o</sub>	0.00V ---- 0.00V ---- 0.00V ----	Displays the Phase to Neutral Voltage Secondary RMS values & Angles with respect to PPS voltage.
Nom Ph-N Voltage Va Vb Vc	0.00V 0.00V 0.00V	Displays the Phase to Neutral Voltage Nominal RMS values
V Seq Components Izps <sub>o</sub> Ipps <sub>o</sub>	0.00V ---- 0.00V ----	Displays the Voltage Sequence components Nominal RMS values & phase angles with respect to PPS voltage.



Inps °	0.00V ----	
Calc Ground Voltage Pri Sec	0.00kV 0.00V ----°	Displays the calculated Ground voltage both primary and secondary which also shows the secondary angle
CS/NVD Voltage (Vx) Pri Sec	0.00kV 0.00V ----°	Displays the 4 <sup>th</sup> voltage (Vx) both primary and secondary which also shows the secondary angle. This voltage can be used for NVD, Vx 27/59 or where available Checksync.
<b>FREQUENCY METERS</b>  →to view		This is the sub-group that includes all the meters that are associated with Frequency TEST/RESET ► allows access to this sub-group
Frequency 00.000Hz		Displays the power system frequency.

<b>POWER METERS</b> →to view		This is the sub-group that includes all the meters that are associated with Power TEST/RESET ► allows access to this sub-group
Phase A Phase B Phase C 0.0MW P (3P)	0.0MW 0.0MW  0.0MW	Displays Real Power
Phase A 0.0MVAr Phase B 0.0MVAr Phase C 0.0MVAr Q (3P) 0.0MVAr		Displays Reactive Power
Phase A 0.0MVA Phase B 0.0MVA Phase C 0.0MVA S (3P) 0.0MVA		Displays Apparent Power
PF A PF B PF C PF (3P)	0.00 0.00 0.00 0.00	Displays Power factor

<b>ENERGY METERS</b> →to view		This is the sub-group that includes all the meters that are associated with Energy TEST/RESET ► allows access to this sub-group
Active Energy Exp Imp	0.00MWh 0.00MWh	Displays both imported and exported Active Energy
Reactive Energy Exp Imp	0.00MVArh 0.00MVArh	Displays both imported and exported Reactive Energy

<b>DIRECTIONAL METERS</b> →to view		This is the sub-group that includes all the meters that are associated with Directional elements TEST/RESET ► allows access to this sub-group. Only seen on models that have the 67 option
P/F Dir (67) ----- - No Dir, PhA Fwd, PhA Rev, PhB Fwd, PhB Rev, PhC Fwd, PhC Rev		The appropriate values from the selection will be displayed.
Meas G/F Dir (67G) ----- - No Dir, G/F Fwd, G/F Rev		The appropriate values from the selection will be displayed.
SGF Dir (67SGF) ----- - No Dir, SGF Fwd, SGF Rev		The appropriate values from the selection will be displayed.

<b>THERMAL METERS</b> →to view	This is the sub-group that includes all the meters that are associated with Thermal TEST/RESET ► allows access to this sub-group
Thermal Status Phase A                   0.0% Phase B                   0.0% Phase C                   0.0%	Displays the thermal capacity

<b>AUTORECLOSE METERS</b> →to view	This is the sub-group that includes all the meters that are associated with Autoreclose TEST/RESET ► allows access to this sub-group. Only seen on models that have the 79 option
79 AR State AR Close Shot            0	

<b>MAINTENANCE METERS</b> →to view	This is the sub-group that includes all the meters that are associated with Maintenance TEST/RESET ► allows access to this sub-group
CB Total Trips Count                    0 Target                   100	Displays the number of CB trips experienced by the CB
CB Delta Trips Count                    0 Target                   100	Displays the number of CB trips experienced by the CB
CB Count To AR Block Count                    0 Target                   100	Displays the number of CB trips experienced by the CB. When the target is reached the relay will only do 1 Delayed Trip to Lockout.
CB Freq Ops Count Count                    0 Target                   10	Displays the number of CB trips experienced by the CB over the last rolling 1 hr period. When the target is reached the relay will only do 1 Delayed Trip to Lockout.
CB LO Handle Ops Count                    0 Target                   10	Displays the number of CB Lockout Handle operations since last reset.
CB Wear Phase A 0.00MA^2s Phase B 0.00MA^2s Phase C 0.00MA^2s	Displays the current measure of circuit breaker wear.

<b>GENERAL ALARM METERS</b> →to view	This is the sub-group that includes all the meters that are associated with the Binary inputs TEST/RESET ► allows access to this sub-group
General Alarms ALARM 1                   Cleared	Displays the state of General Alarm
General Alarms ALARM 2                   Cleared	
General Alarms ALARM 3                   Cleared	
General Alarms ALARM 4                   Cleared	
General Alarms ALARM 5                   Cleared	
General Alarms	

ALARM 6	Cleared	
General Alarms ALARM 7	Cleared	
General Alarms ALARM 8	Cleared	
General Alarms ALARM 9	Cleared	
General Alarms ALARM 10	Cleared	
General Alarms ALARM 11	Cleared	
General Alarms ALARM 12	Cleared	

<b>BINARY INPUT METERS</b>  →to view	This is the sub-group that includes all the meters that are associated with the Binary inputs TEST/RESET ► allows access to this sub-group
BI 1-8                ---- ---- BI 9-13              ---- -	Displays the state of DC binary inputs 1 to 8 (The number of binary inputs may vary depending on model)

<b>BINARY OUTPUT METERS</b>  →to view	This is the sub-group that includes all the meters that are associated with the Binary Outputs TEST/RESET ► allows access to this sub-group
BO 1-8                ---- ---- BO 9-14              ---- -	Displays the state of DC binary Outputs 1 to 8. (The number of binary outputs may vary depending on model)

<b>VIRTUAL METERS</b>  →to view	This is the sub-group that shows the state of the virtual status inputs in the relay TEST/RESET ► allows access to this sub-group
V 1-8                 ---- ---- V 9-16                ---- ----	Displays the state of Virtual Outputs 1 to 16 (The number of virtual inputs will vary depending on model)

<b>COMMUNICATION METERS</b>  →to view	This is the sub-group that includes all the meters that are associated with Communications ports TEST/RESET ► allows access to this sub-group
COM1 COM2 COM3 COM4	Displays which com ports are currently active
COM1 TRAFFIC Tx1                    0 Rx1                    0 Rx1 Errors           0	Displays traffic on Com1
COM2 TRAFFIC Tx2                    0 Rx2                    0 Rx2 Errors           0	Displays traffic on Com2
COM3 TRAFFIC Tx3                    0 Rx3                    0 Rx3 Errors           0	Displays traffic on Com3
COM4 TRAFFIC Tx4                    0 Rx4                    0 Rx4 Errors           0	Displays traffic on Com4

<b>MISCELLANEOUS METERS</b> →to view	This is the sub-group that includes indication such as the relays time and date, the amount of fault and waveform records stored in the relay TEST/RESET ► allows access to this sub-group
Date 01/01/2000 Time 22:41:44 Waveform Recs                   0 Fault Recs                         0	This meter displays the date and time and the number of Fault records and Event records stored in the relay
Event Recs                         0 Data Log Recs                    0	